

Prezentacja rysunków do ZO:

**Wykonanie metalowych
konstrukcji pomocniczych linii
produkcyjnej (zbiorniki, podpory,
elementy wsporcze)**

04.12.2024

Piotr Zakrzewski
Specjalista ds. inwestycji

Zakres nr 1 do Zapytania Ofertowego - – podpory pod rurę wulkanizacyjną

Zestawienie ilości oraz długości podpór do wykonania zgodnie ze specyfikacją w tabeli dla danej linii.

Linia A:

- 43 sztuk podpór łącznie
- 4 typy podpór o różnych długościach i ilościach:
 - podpora typu A = 5 szt.
 - podpora typu B = 6 szt.
 - podpora typu C = 5 szt.
 - podpora typu D = 27 szt.

Linia D:

- 39 sztuk podpór łącznie
- 5 typów podpór o różnych długościach i ilościach:
 - podpora typu A = 5 szt.
 - podpora typu B = 1 szt.
 - podpora typu C = 5 szt.
 - podpora typu D = 4 szt.
 - podpora typu E = 24 szt.

Linia A i D:

- łącznie 82 sztuki podpór:
 - Podpora typu A = 10 szt.
 - Podpora typu B = 7 szt.
 - Podpora typu C = 10 szt.
 - Podpora typu D = 31 szt.
 - Podpora typu E = 24 szt.

1.a.1. Rzut rysunku montażu podpór rury wulkanizacyjnej linia A

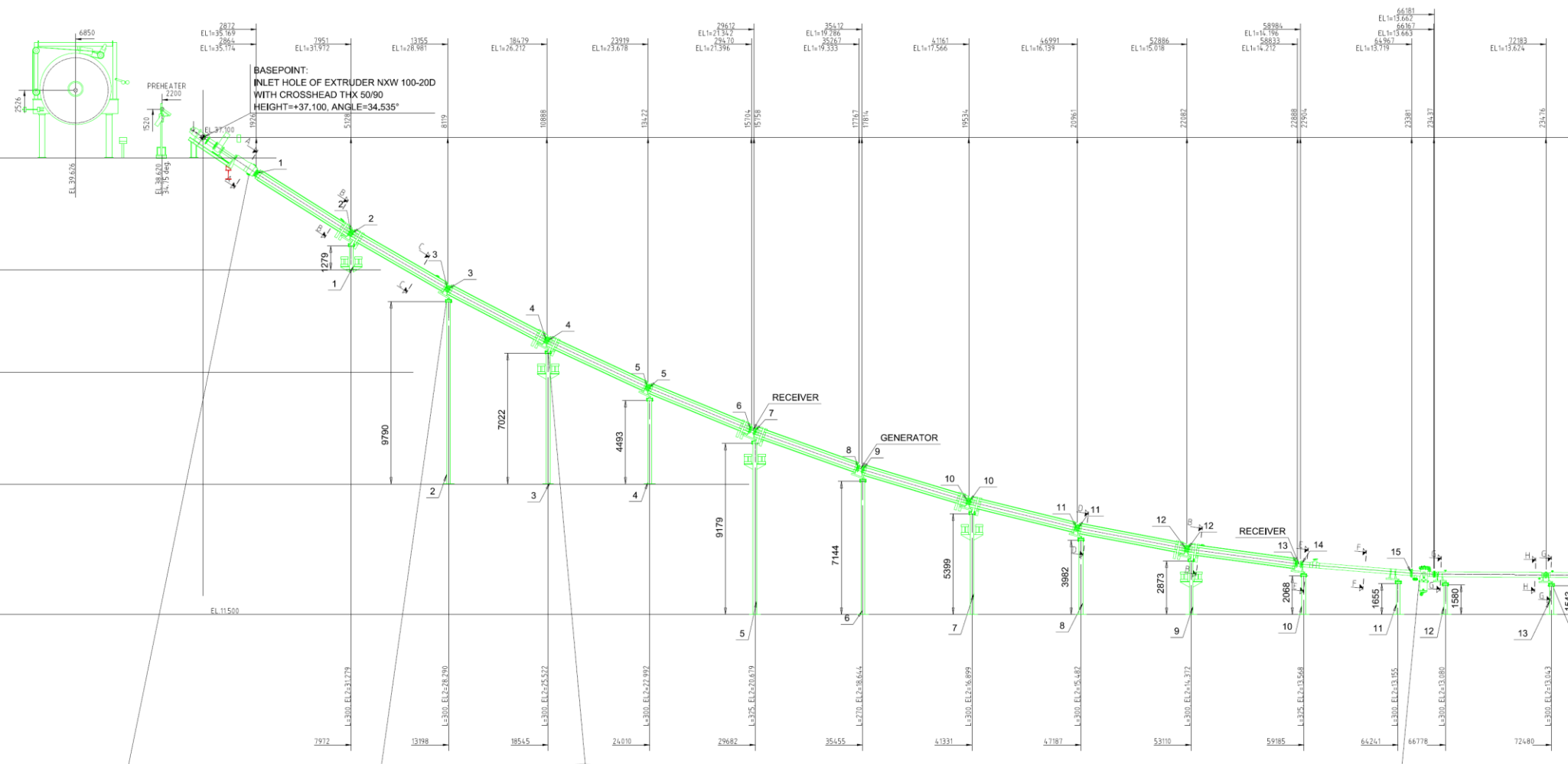

1.a.2 Rzut rysunku montażu podpór rury wulkanizacyjnej linia A

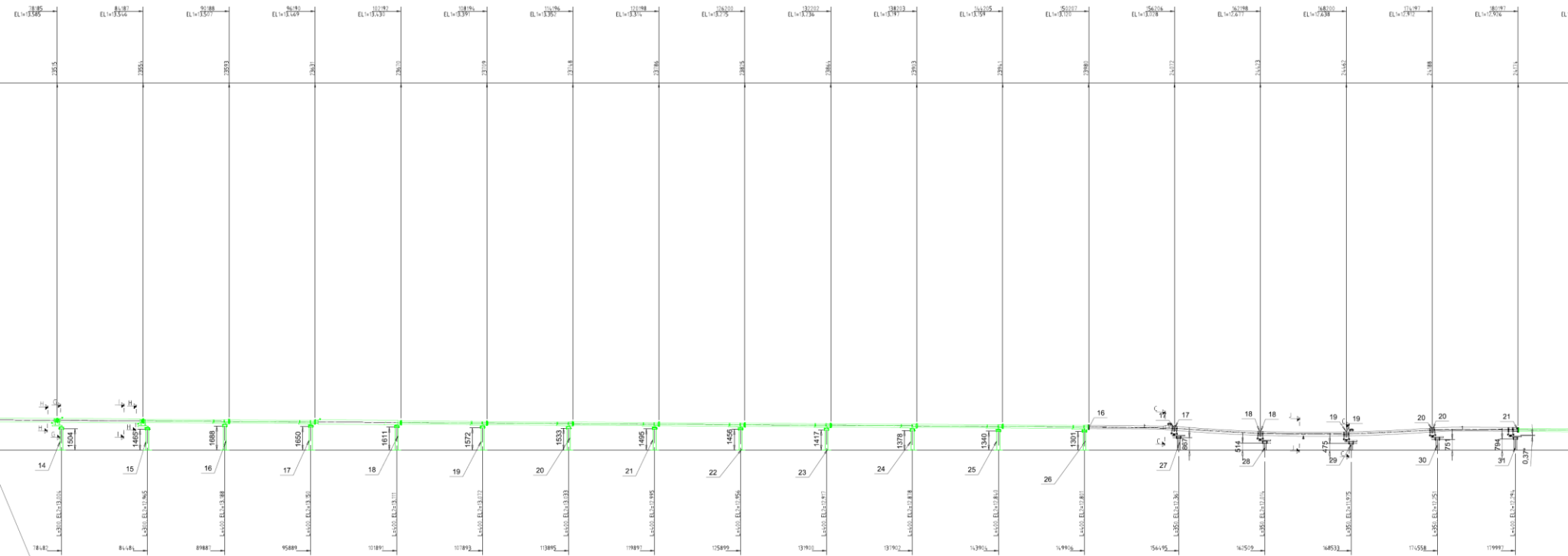

1.a.T Tabela zestawiająca długości podpór dla linii A



Długości dla pozycji z gwiazdką przyjęć z rysunku montażu rury wulkanizacyjnej.

SUPPORT	MODEL	HEIGHT (EL.), MM	DIST. FROM BASE POINT
1	A	1279 (from +30.000)	7972
2	B	*) (from +18.500)	13198
3	A	*) (from +18.500)	18545
4	C	4492 (from +18.500)	24010
5	A	*) (from +11.500)	29682
6	C	*) (from +11.500)	35455
7	A	5399 (from +11.500)	41331
8	C	3982 (from +11.500)	47187
9	A	2872 (from +11.500)	53110
10	C	2068 (from +11.500)	59185
11	C	1655 (from +11.500)	64241
12	D	1580 (from +11.500)	66778
13	D	1543 (from +11.500)	72480
14	D	1504 (from +11.500)	78482
15	D	1465 (from +11.500)	84484
16	D	1688 (from +11.500)	89887
17	D	1650 (from +11.500)	95889
18	D	1611 (from +11.500)	101891
19	D	1572 (from +11.500)	107893
20	D	1533 (from +11.500)	113895
21	D	1495 (from +11.500)	119897
22	D	1456 (from +11.500)	125899
23	D	1417 (from +11.500)	131900
24	D	1378 (from +11.500)	137902
25	D	1340 (from +11.500)	143904
26	D	1301 (from +11.500)	149906
27	B	867 (from +11.500)	156495
28	B	514 (from +11.500)	162509
29	B	475 (from +11.500)	168533
30	B	751 (from +11.500)	174558
31	B	794 (from +11.500)	179997
32	D	1068 (from +11.500)	185898
33	D	1030 (from +11.500)	191900
34	D	991 (from +11.500)	197901
35	D	952 (from +11.500)	203903
36	D	913 (from +11.500)	209905
37	D	875 (from +11.500)	215907
38	D	836 (from +11.500)	221909
39	D	797 (from +11.500)	227911
40	D	758 (from +11.500)	233913
41	D	720 (from +11.500)	239922
42	D	681 (from +11.500)	245930
43	D	679 (from +11.500)	250450

1.b.1. Rzut rysunku montażu podpór rury wulkanizacyjnej linia D

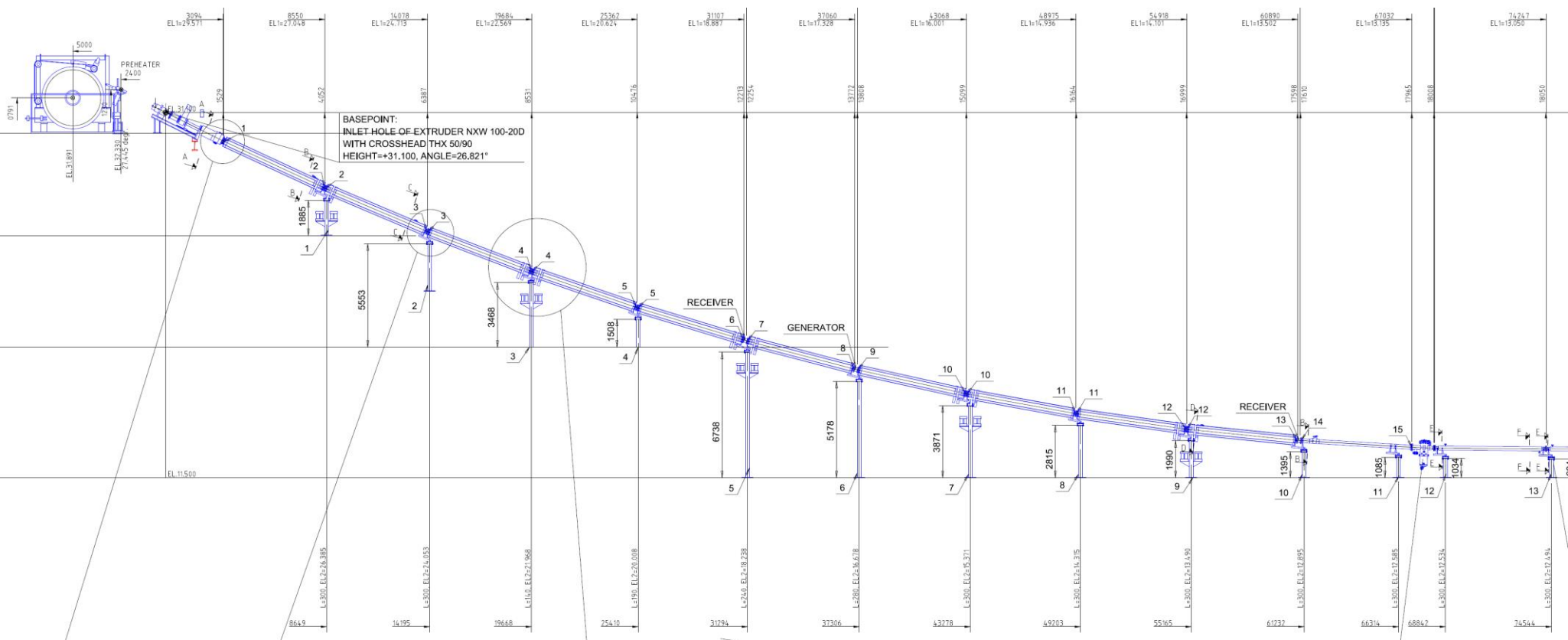

1.b.2. Rzut rysunku montażu podpór rury wulkanizacyjnej linia D

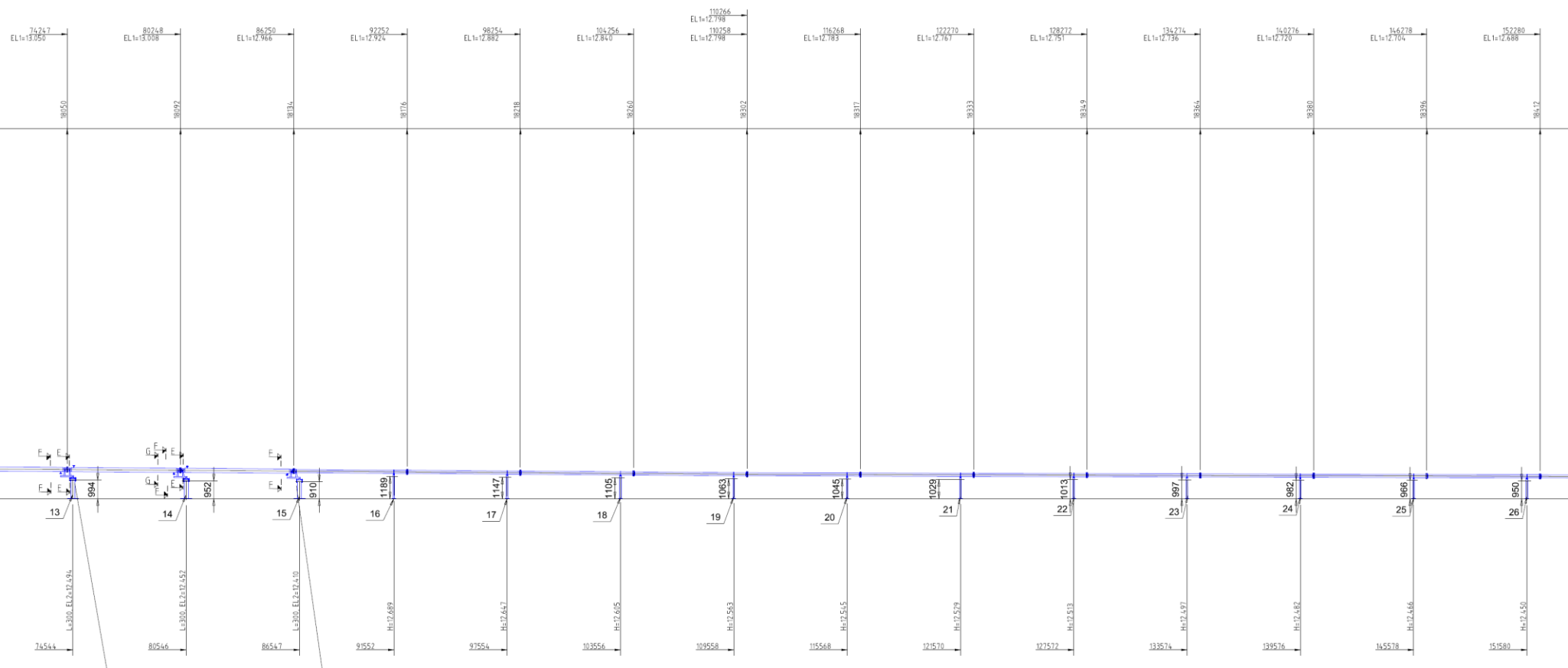

1.b.3. Rzut rysunku montażu podpór rury wulkanizacyjnej linia D

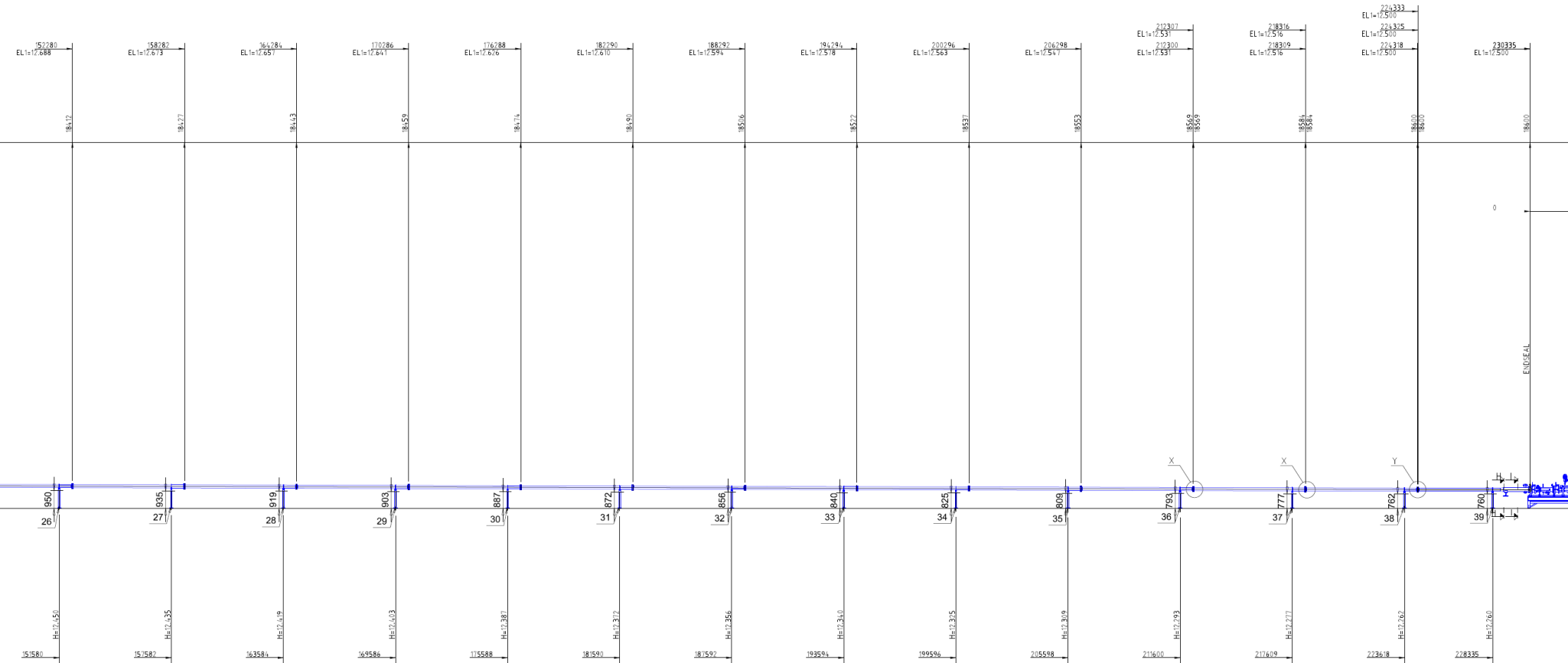

1.b.T. Tabela zestawiająca długości podpór dla linii D



Długości dla pozycji z gwiazdką przyjąc z rysunku montażu rury wulkanizacyjnej.

SUPPORT	MODEL	HEIGHT (EL.), MM	DIST. FROM BASE POINT
1	A	1885 (from +24.500)	8649
2	B	5553 (from +18.500)	14195
3	A	3468 (from +18.500)	19668
4	C	1508 (from +18.500)	25410
5	A	*) (from +11.500)	31294
6	C	5178 (from +11.500)	37306
7	A	3871 (from +11.500)	43278
8	C	2815 (from +11.500)	49203
9	A	1990 (from +11.500)	55165
10	C	1395 (from +11.500)	61232
11	C	1085 (from +11.500)	66314
12	D	1034 (from +11.500)	68842
13	D	994 (from +11.500)	74544
14	D	952 (from +11.500)	80546
15	D	910 (from +11.500)	86547
16	E	1189 (from +11.500)	91552
17	E	1147 (from +11.500)	97554
18		1105 (from +11.500)	103556
19		1063 (from +11.500)	109558
20		1045 (from +11.500)	115568
21		1029 (from +11.500)	121570
22		1013 (from +11.500)	127572
23		997 (from +11.500)	133574
24		982 (from +11.500)	139576
25		966 (from +11.500)	145578
26		950 (from +11.500)	151580
27		935 (from +11.500)	157582
28		919 (from +11.500)	163584
29		903 (from +11.500)	169586
30		887 (from +11.500)	175588
31		872 (from +11.500)	181590
32		856 (from +11.500)	187592
33		840 (from +11.500)	193594
34		825 (from +11.500)	199596
35		809 (from +11.500)	205598
36		793 (from +11.500)	211600
37		777 (from +11.500)	217609
38		762 (from +11.500)	223618
39		760 (from +11.500)	228335

E

*) HEIGHT ACCORDING TO LEVEL OF STEEL STRUCTURE TO BE DETERMINED BY CUSTOMER

1.1. Podpora typ A

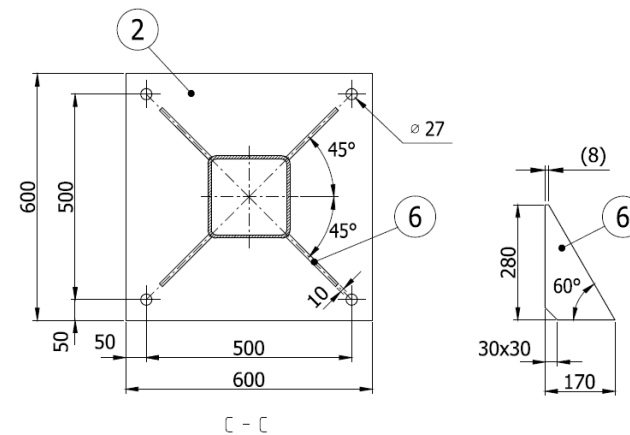
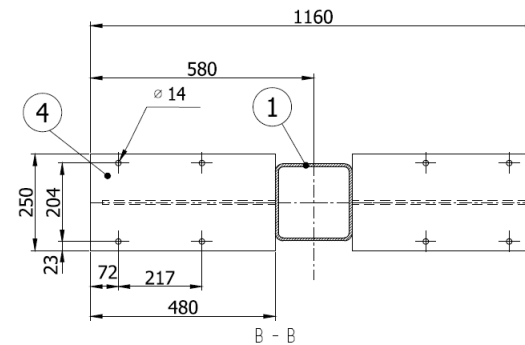
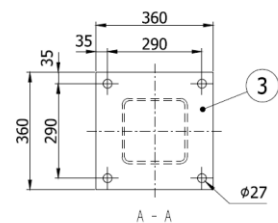
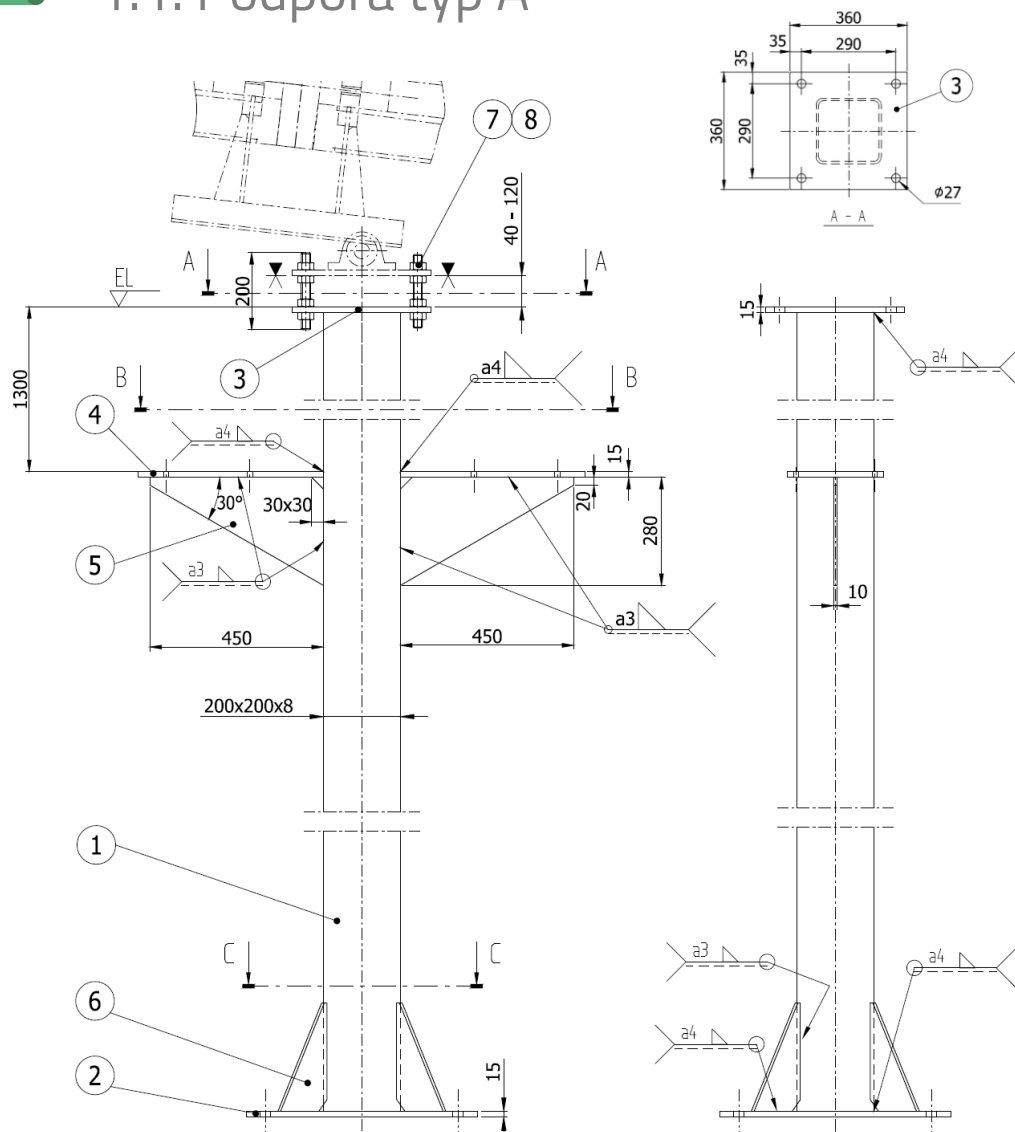

POS.	PCS	NAME	MATERIAL
8	16	NUT M24 DIN934	8.8 ZNC
7	4	THREADED ROD M24x200	Fe52 C ZNC
6	4	PLATE 10x170x280	S355J2G3
5	2	PLATE 10x280x450	S355J2G3
4	2	PLATE 15x250x480	S355J2G3
3	1	PLATE 15x360x360	S355J2G3
2	1	PLATE 15x600x600	S355J2G3
1	1	SQUARE TUBE 200x8	S355J2H

1.2. Podpora typ B

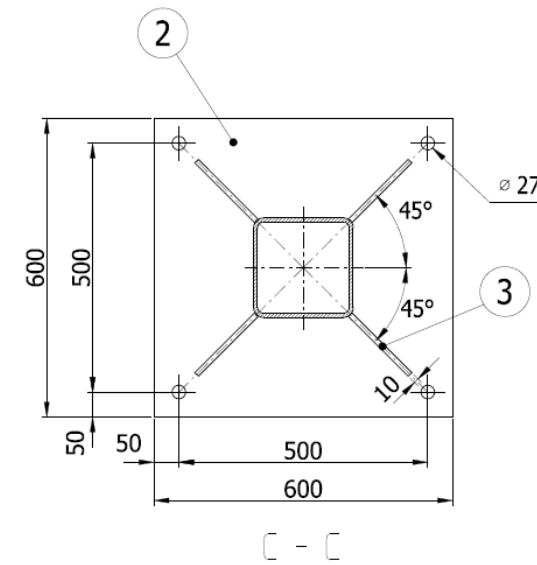
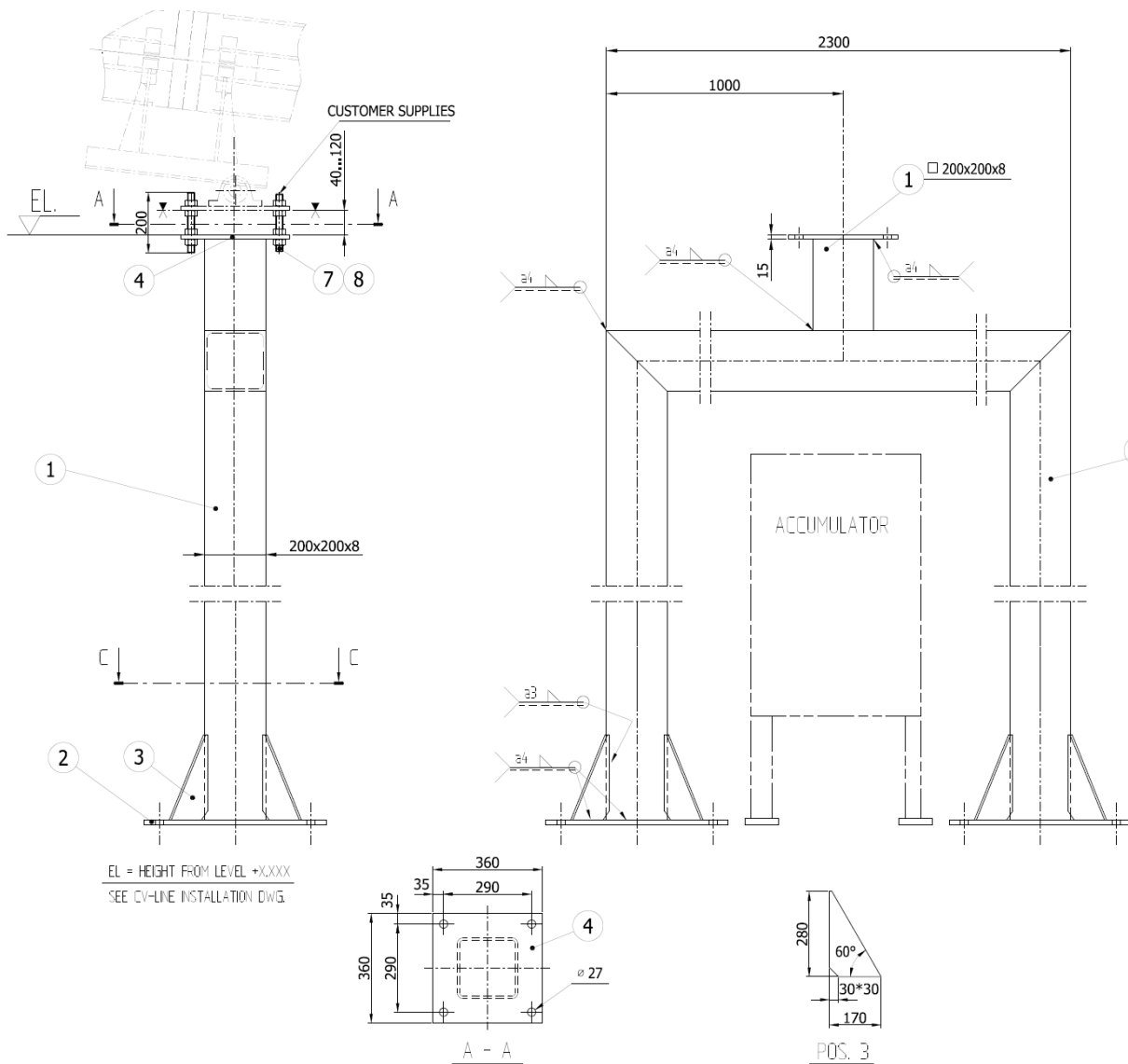

8	16	NUT M24	8 ZNC DIN934	
7	4	THREADED ROD M24*200	St52.3 ZNC	
6	2	PLATE 10*280*450	St52.3	
4	1	PLATE 15*360*360	St52.3	
3	8	PLATE 10*170*280	St52.3	
2	2	PLATE 15*600*600	St52.3	
1		SQUARE TUBE 200*200*8	St44.4 DIN59410	
POS.	CODE	PCS	NAME	MATERIAL
GENERAL TOLERANCES		SOURCE		MATERIAL
MACHINING	WELDING	OXYGEN CUTTING		
ISO 2768-m	DN 8570-B	DN 2310-A		

1.3. Podpora typ C

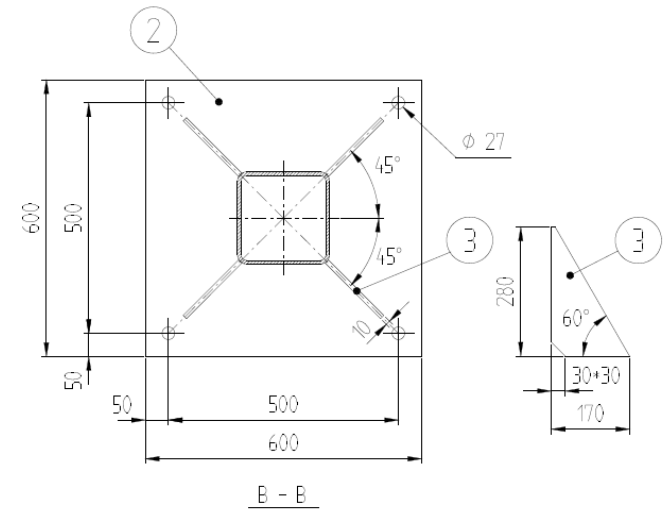
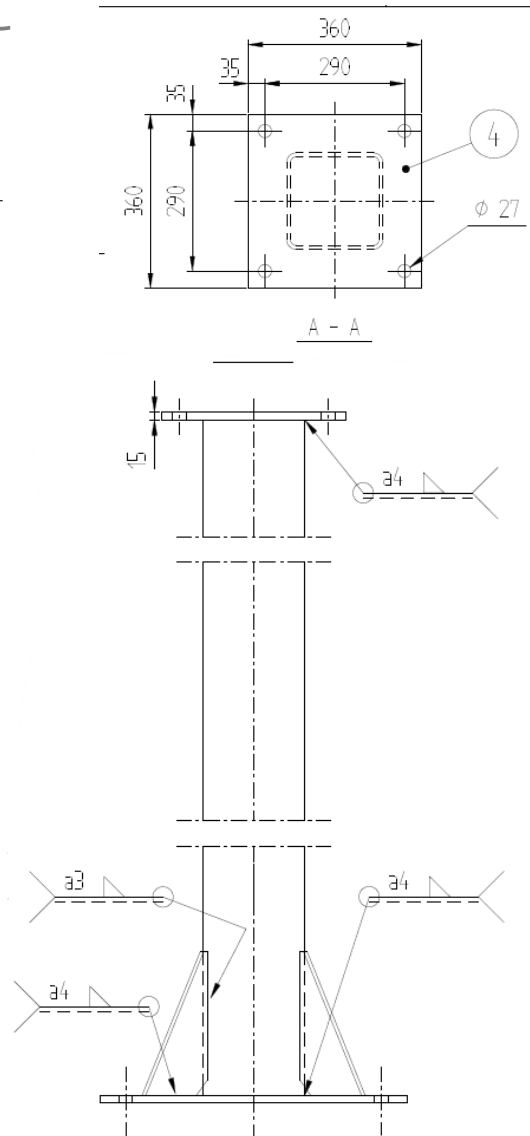
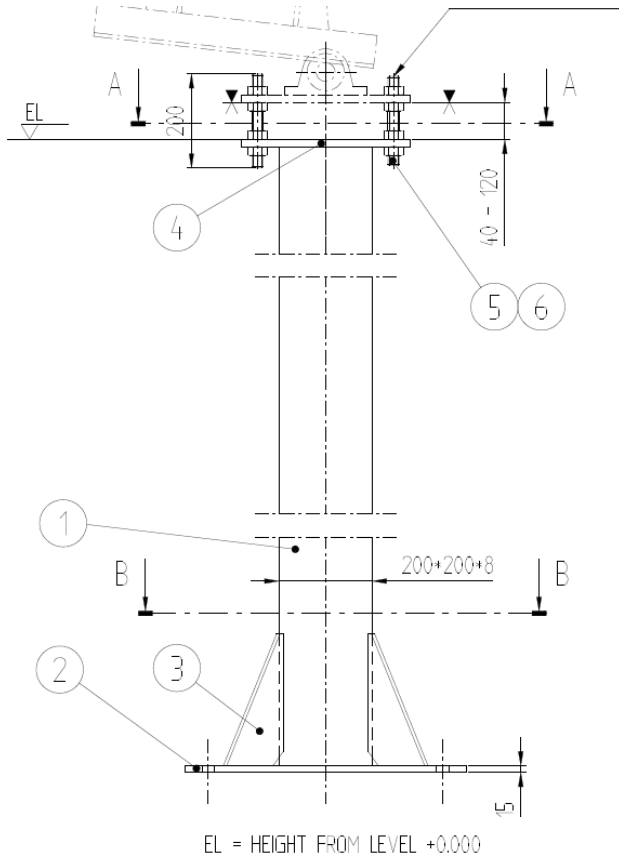

6	16	NUT M24	8 ZNC DIN934
5	4	THREADED ROD M24*200	SI52.3 ZNC
4	1	PLATE 15*360*360	SI52.3
3	4	PLATE 10*170*280	SI52.3
2	1	PLATE 15*600*600	SI52.3
1	1	SQUARE TUBE 200*8	SI44.4 DIN59410

1.4. Podpora typ D

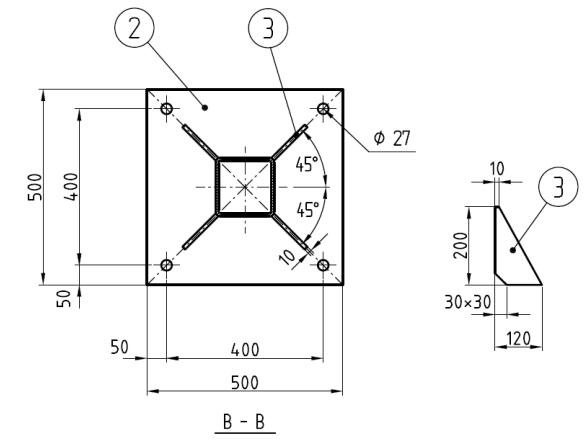
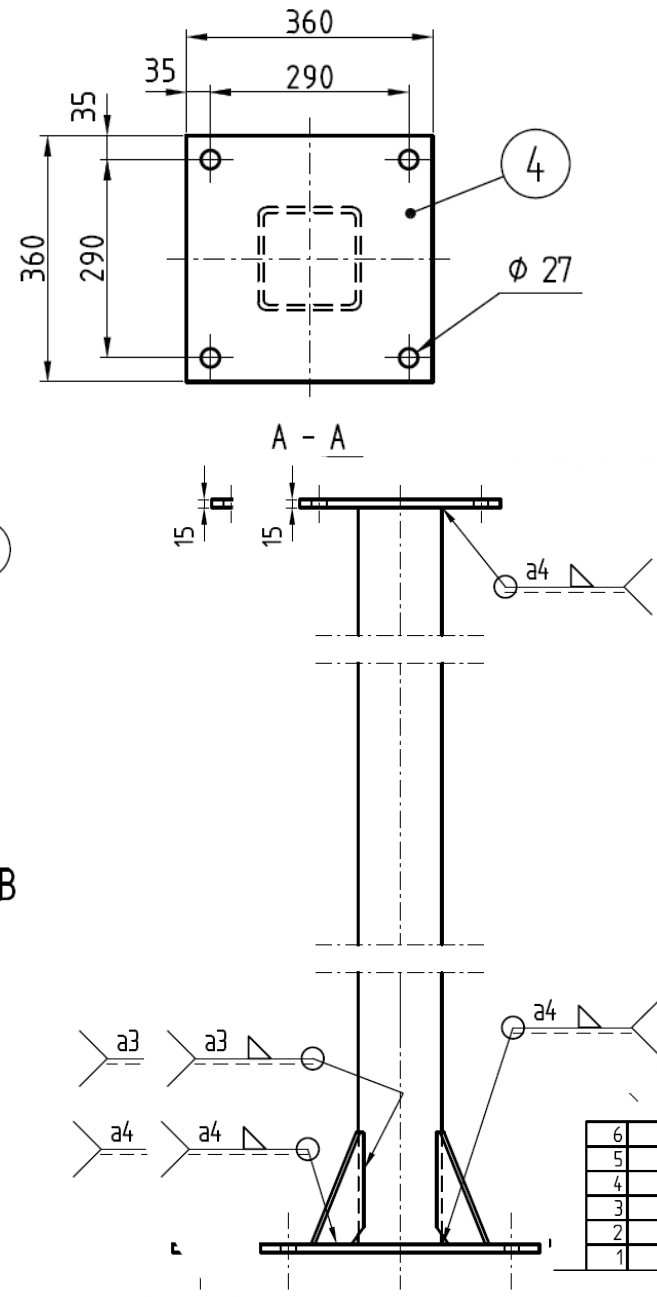
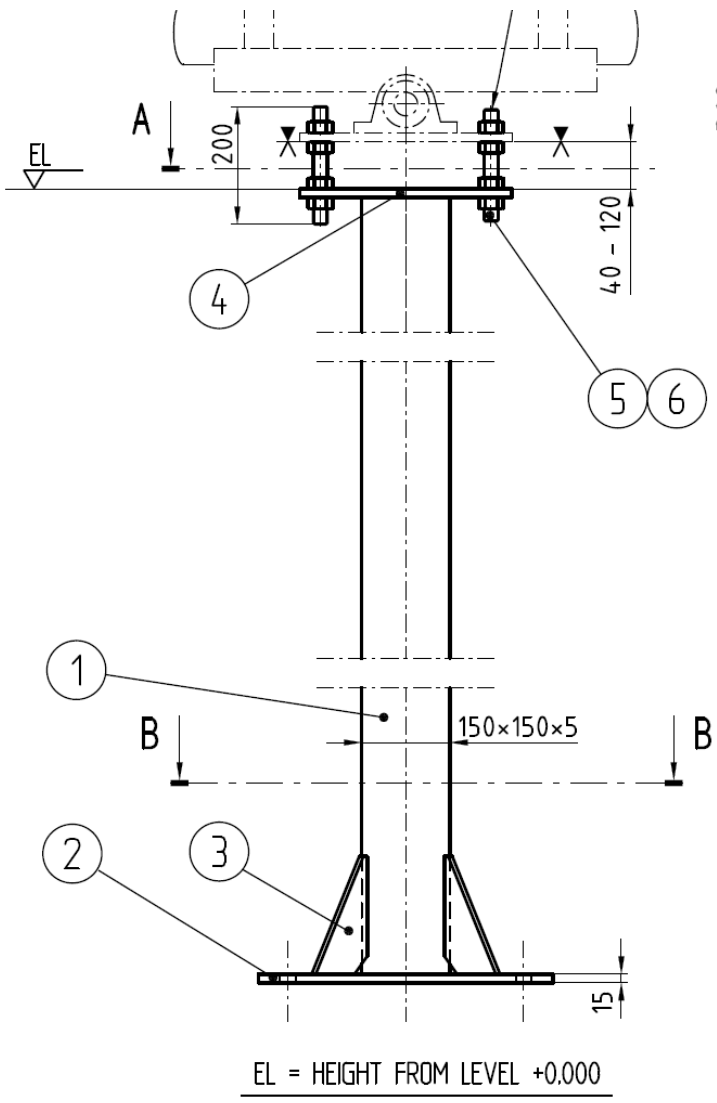

6	16	NUT M24	8 ZNC DIN934
5	4	THREADED ROD M24*200	SI52.3 ZNC
4	1	PLATE 15*360*360	SI52.3
3	4	PLATE 10*120*200	SI52.3
2	1	PLATE 15*500*500	SI52.3
1	1	SQUARE TUBE 150*5	SI44.4 DIN59410

1.5. Podpora typu E

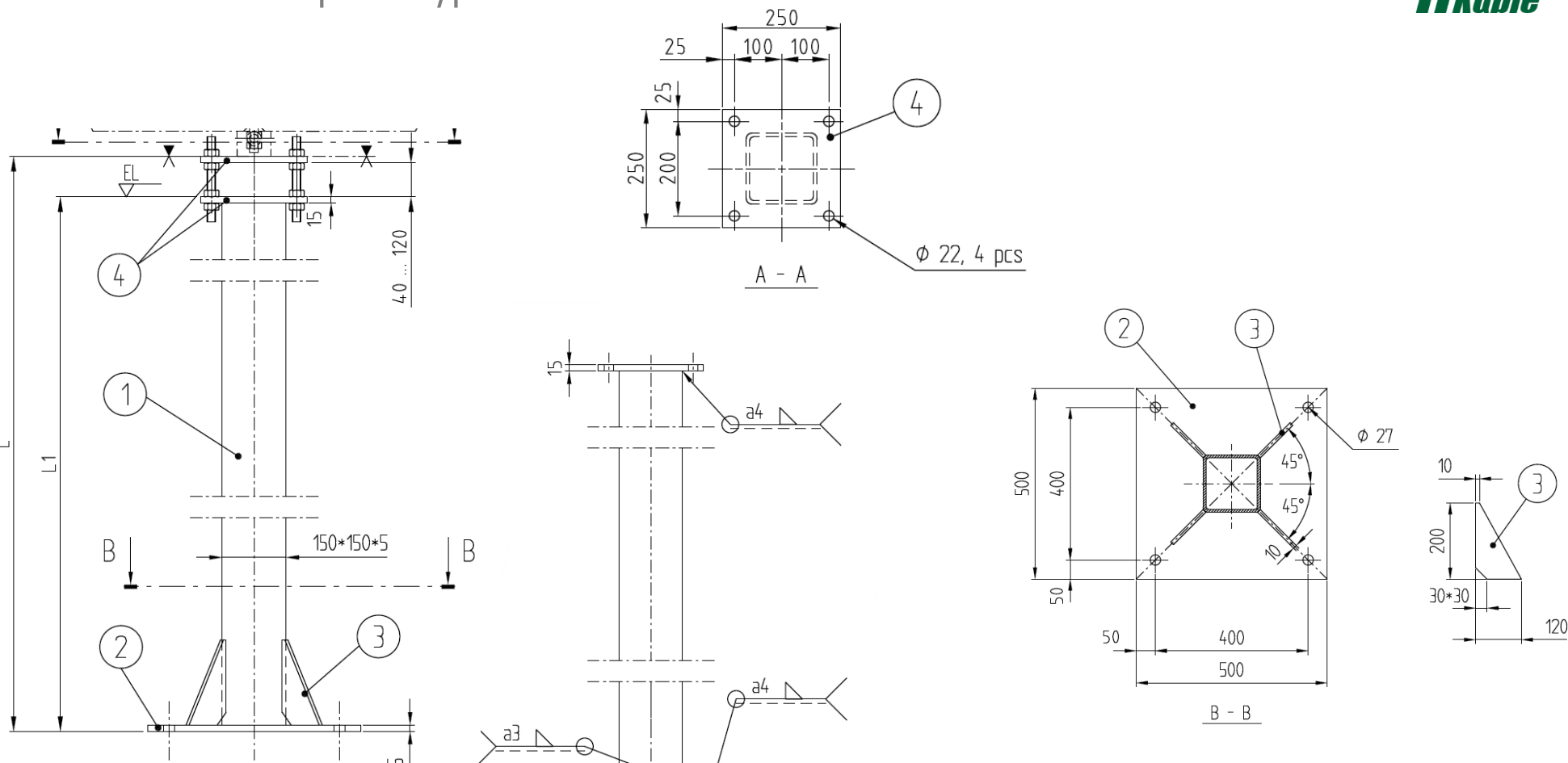

EL = HEIGHT FROM LEVEL +0.000
 HEIGHT OF SUPPORT COLUMN:
 $L1 = L - 95 \text{ mm}$

6	16	NUT M20	8 ZNC DIN934
5	4	THREADED ROD M20*200	S152.3 ZNC
4	2	PLATE 15*250*250	S152.3
3	4	PLATE 10*120*200	S152.3
2	1	PLATE 15*500*500	S152.3
1	1	SQUARE TUBE 150*5	S144.4 DIN59410
POS.	CODE	PCS	NAME MATERIAL

Zakres nr 2 do Zapytania Ofertowego - - Zbiorniki

2.1. Zbiornik nr 1 – 4 szt.

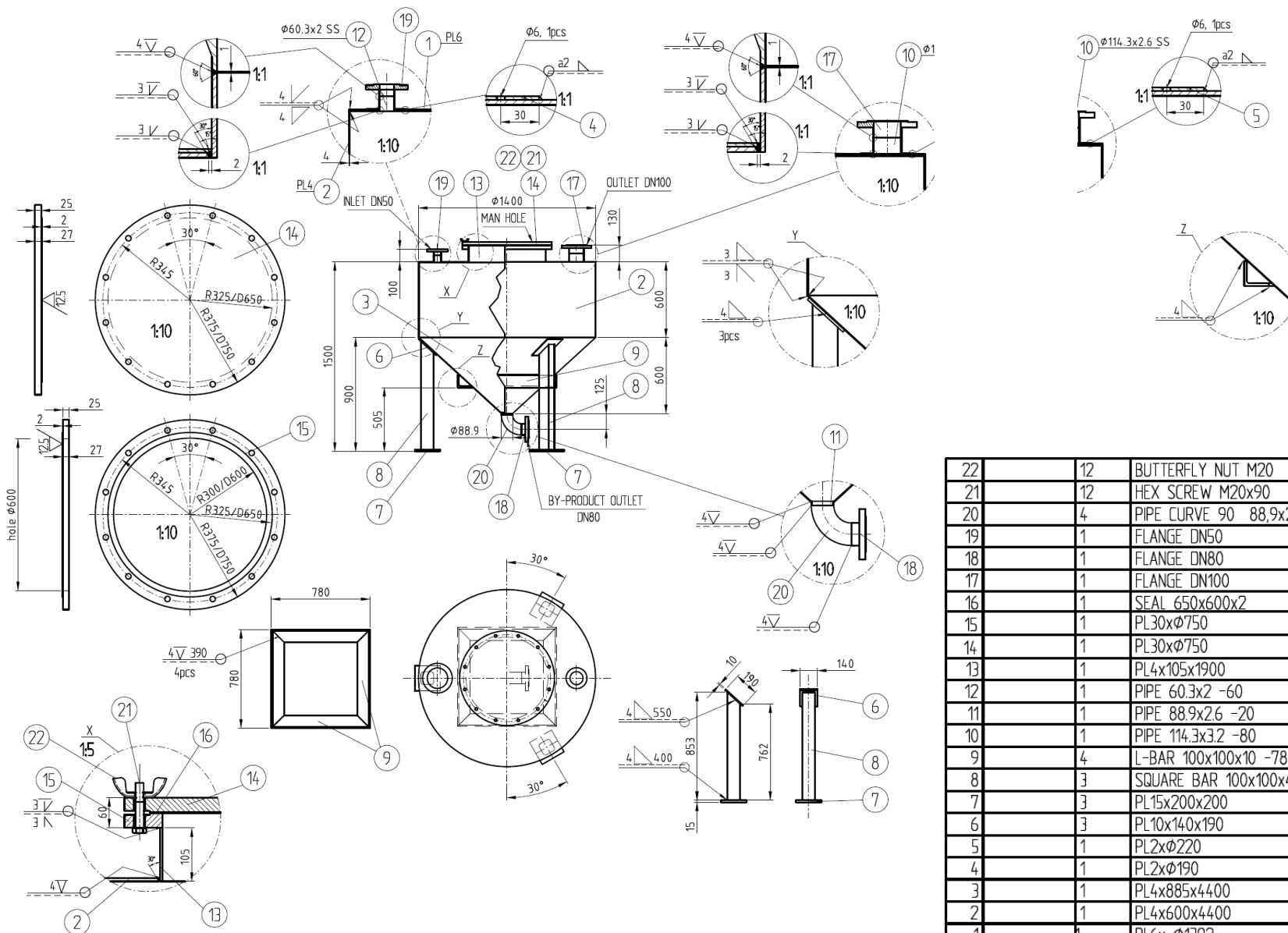

22	12	BUTTERFLY NUT M20	8 DIN315 ZNC
21	12	HEX SCREW M20x90	8 DIN934 ZNC
20	4	PIPE CURVE 90 88,9x2,6	W14301
19	1	FLANGE DN50	W14301
18	1	FLANGE DN80	W14301
17	1	FLANGE DN100	W14301
16	1	SEAL 650x600x2	RUBBER
15	1	PL30xφ750	W14301
14	1	PL30xφ750	W14301
13	1	PL4x105x1900	W14301
12	1	PIPE 60.3x2 -60	W14301
11	1	PIPE 88.9x2.6 -20	W14301
10	1	PIPE 114.3x3.2 -80	W14301
9	4	L-BAR 100x100x10 -780	W14301
8	3	SQUARE BAR 100x100x4-853	W14301
7	3	PL15x200x200	W14301
6	3	PL10x140x190	W14301
5	1	PL2xφ220	W14301
4	1	PL2xφ190	W14301
3	1	PL4x885x4400	W14301
2	1	PL4x600x4400	W14301
1	1	PL6x φ1392	W14301

2.2. Zbiornik nr 2 – 1 szt. linia A

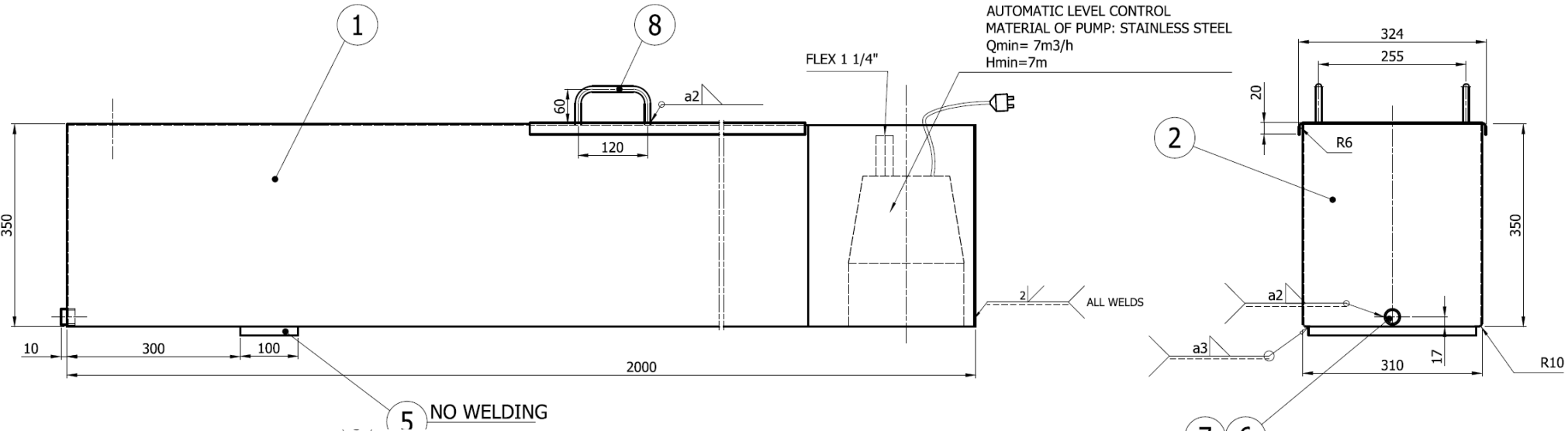

SUBMERSIBLE PUMP WITH
AUTOMATIC LEVEL CONTROL
MATERIAL OF PUMP: STAINLESS STEEL
Qmin= 7m3/h
Hmin=7m

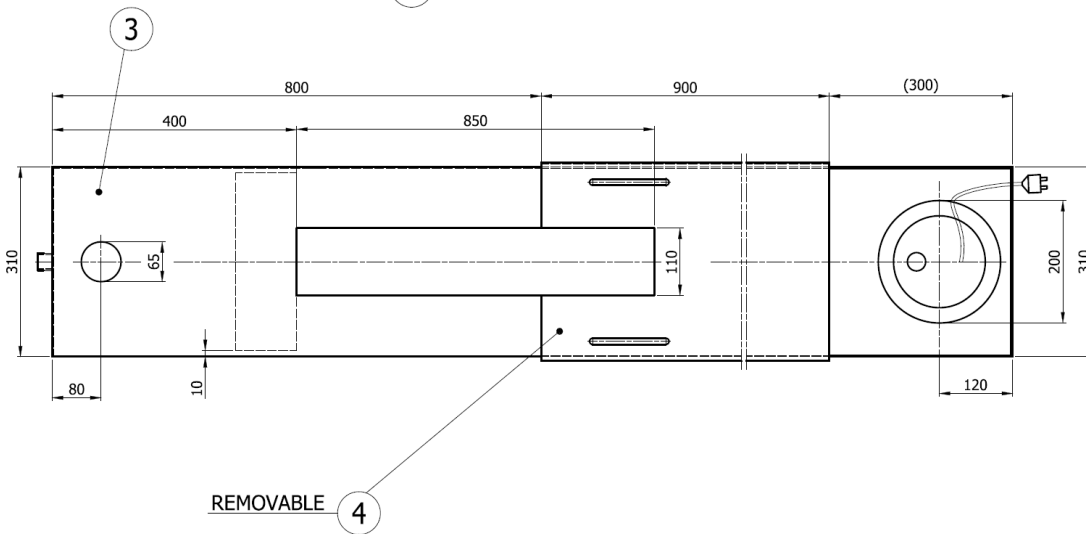

UWAGA!
W dostawie uwzględnić pompę
zgodnie z powyższymi wymogami.

8	2	ROUND BAR $\varnothing 10$ L=250	AISI 304	
7	1	PLUG R1"	AISI 304	
6	1	COUPLING R1"	AISI 304	
5	1	PLATE PL15x100 L=290	S235JRG2	
4	1	PLATE PL2x351x900	AISI 304	
3	1	PLATE PL2x307x798	AISI 304	
2	2	PLATE PL2x306x348	AISI 304	
1	1	PLATE PL2x1002x1996	AISI 304	
POS.	CODE	PCS	NAME	MATERIAL
GENERAL TOLERANCES		SOURCE		MATERIAL
MACHINING	WELDING	OXYGEN CUTTING		
ISO 2768-m	DIN 8570-B	DIN 2310-A		

2.3. Zbiornik nr 2 – 1 szt. linia D

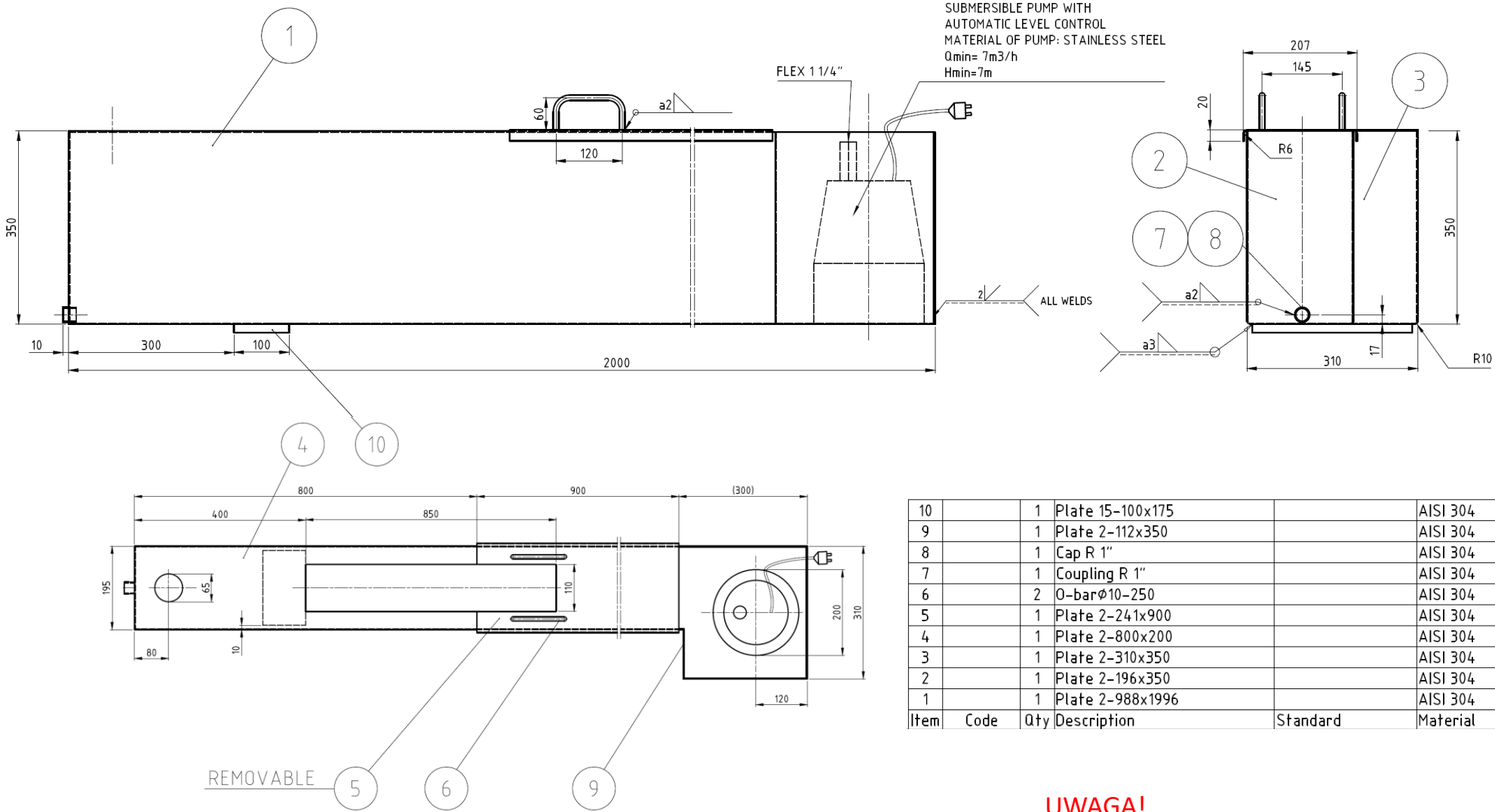

Item	Code	Qty	Description	Standard	Material
10	1	1	Plate 15-100x175		AISI 304
9	1	1	Plate 2-112x350		AISI 304
8	1	1	Cap R 1"		AISI 304
7	1	1	Coupling R 1"		AISI 304
6	2	2	O-bar $\varnothing 10-250$		AISI 304
5	1	1	Plate 2-241x900		AISI 304
4	1	1	Plate 2-800x200		AISI 304
3	1	1	Plate 2-310x350		AISI 304
2	1	1	Plate 2-196x350		AISI 304
1	1	1	Plate 2-988x1996		AISI 304

UWAGA!

W dostawie uwzględnić pompę zgodnie z powyższymi wymogami.

2.4. Zbiornik nr 3 – (linia D) 1 szt.

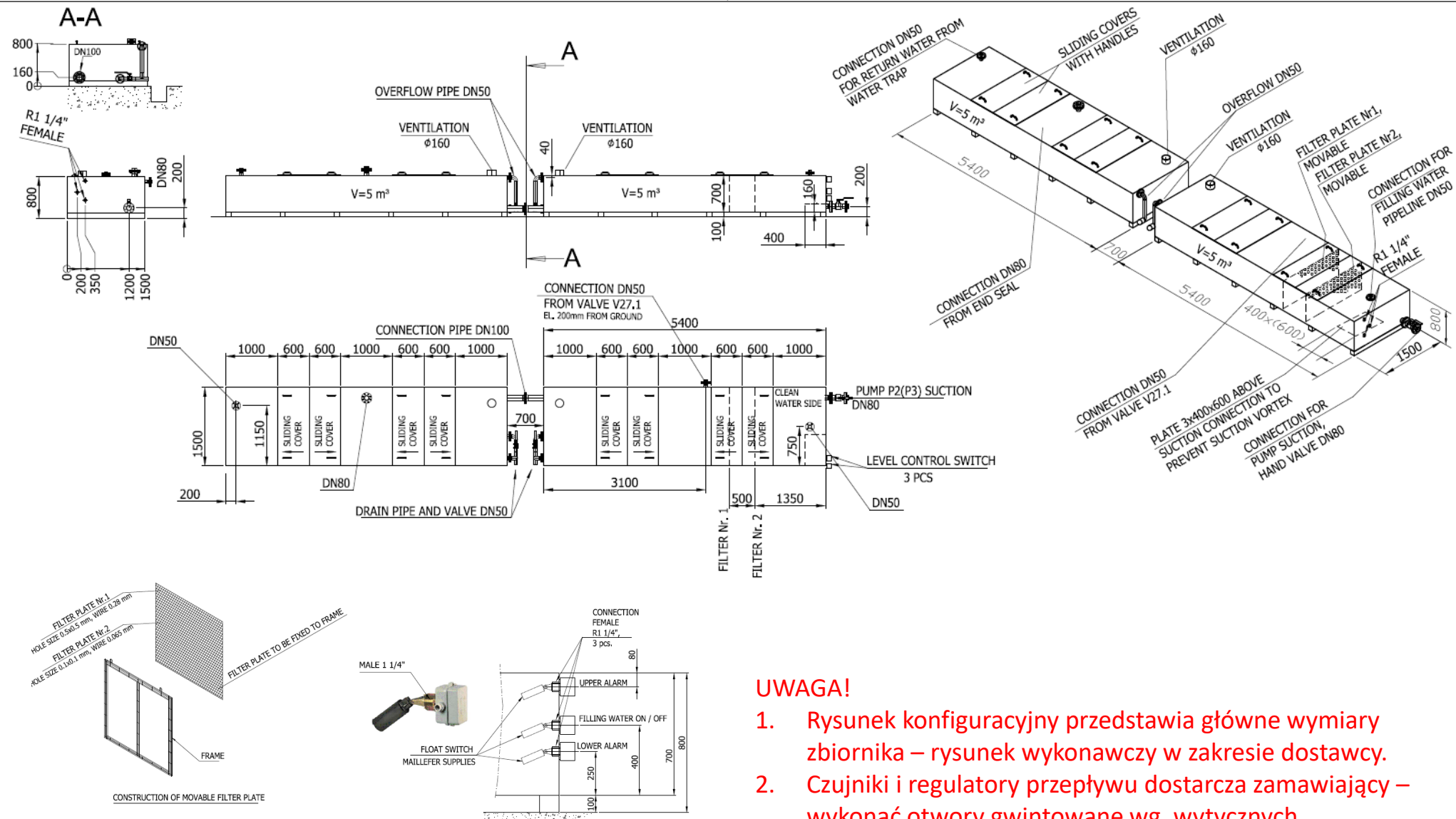

UWAGA!

1. Rysunek konfiguracyjny przedstawia główne wymiary zbiornika – rysunek wykonawczy w zakresie dostawy.
2. Czujniki i regulatory przepływu dostarcza zamawiający – wykonać otwory gwintowane wg. wytycznych.

2.5. Zbiornik nr 4 – (linia A) 1 szt.

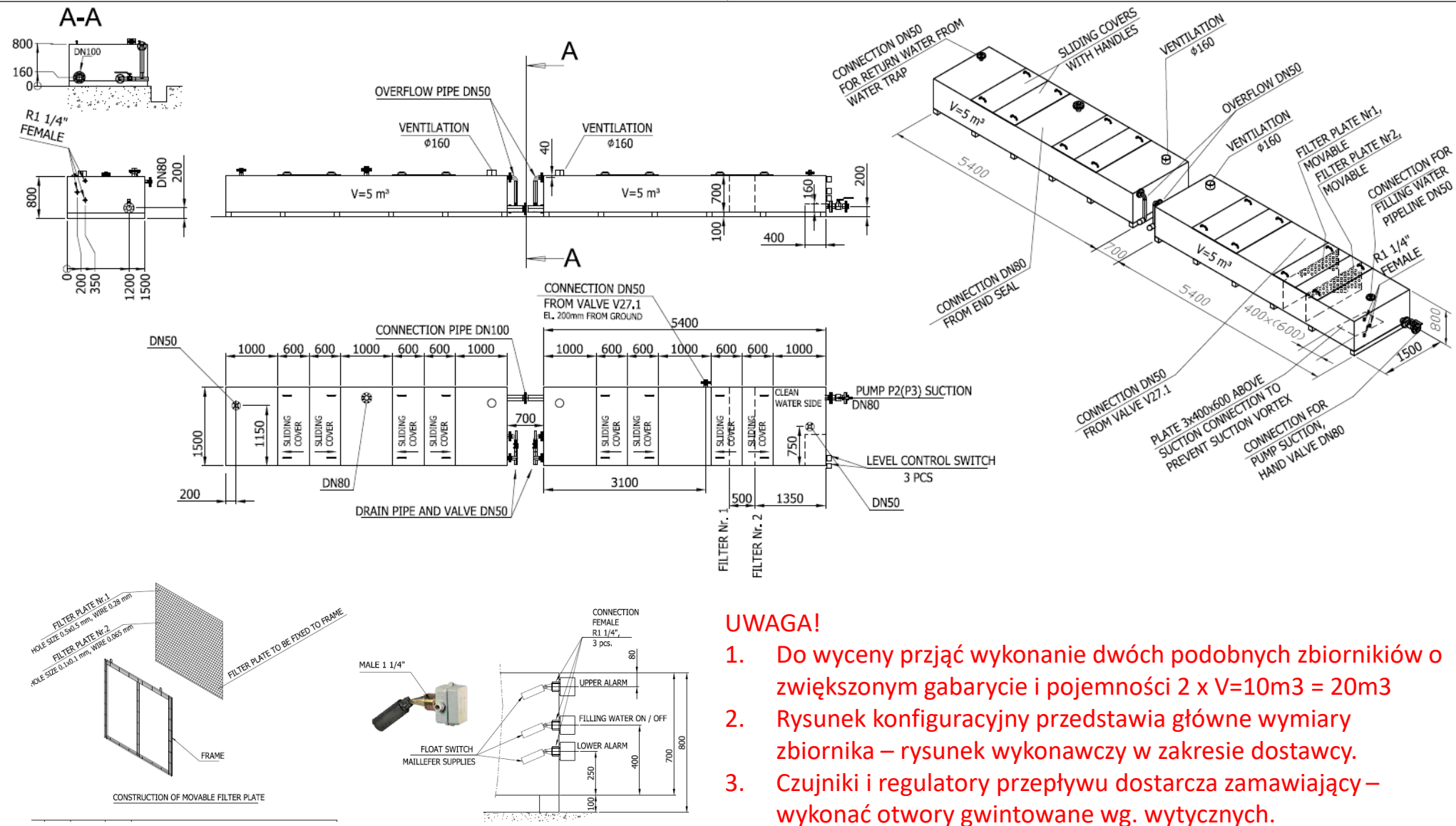

UWAGA!

1. Do wyceny prjąć wykonanie dwóch podobnych zbiorników o zwiększonym gabarycie i pojemności $2 \times V=10\text{m}^3 = 20\text{m}^3$
2. Rysunek konfiguracyjny przedstawia główne wymiary zbiornika – rysunek wykonawczy w zakresie dostawy.
3. Czujniki i regulatory przepływu dostarcza zamawiający – wykonać otwory gwintowane wg. wytycznych.

Zakres nr 3 do Zapytania Ofertowego – - Pozostałe elementy

3.1. Konstrukcja bazy uszczelnienia końcowego linia D – 1 szt.

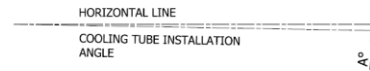

DIMENSIONS H1 ... H6 ACCORDING TO COOLING TUBE HEIGHT AND INSTALLATION ANGLE. SEE LAYOUT DRAWING

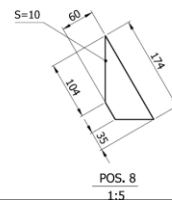
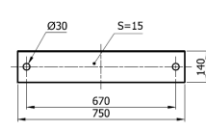
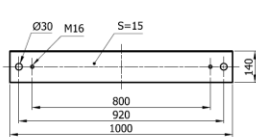
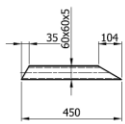
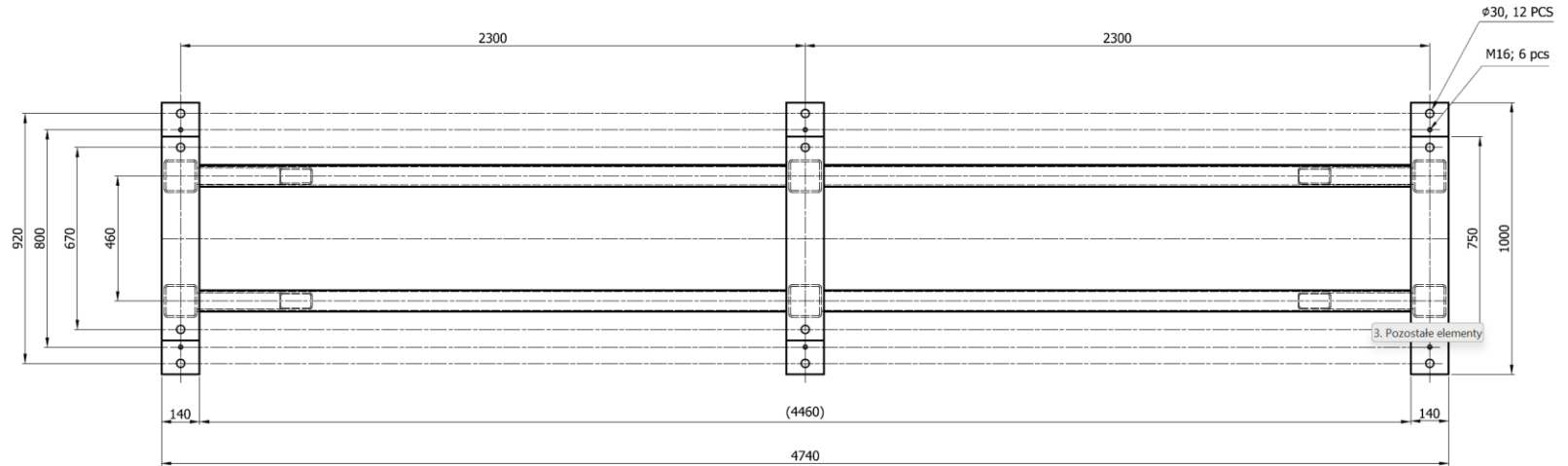
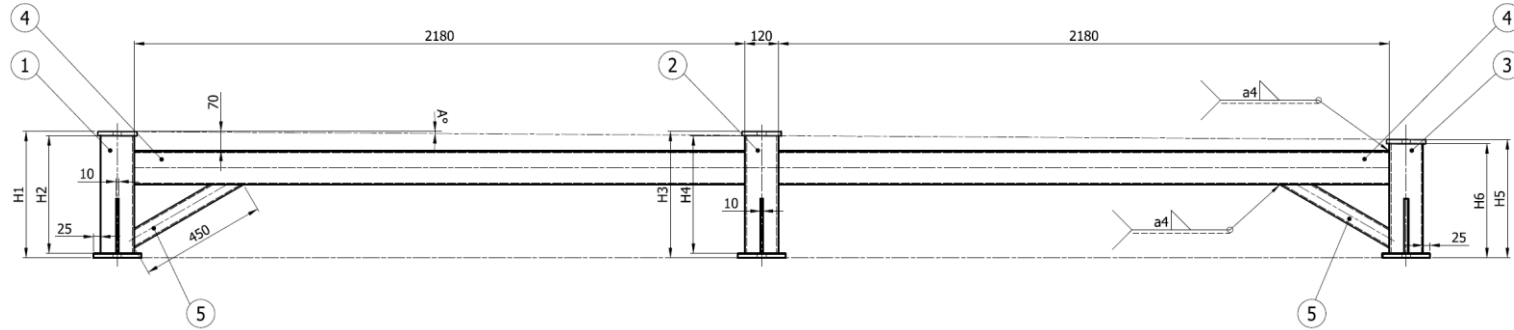
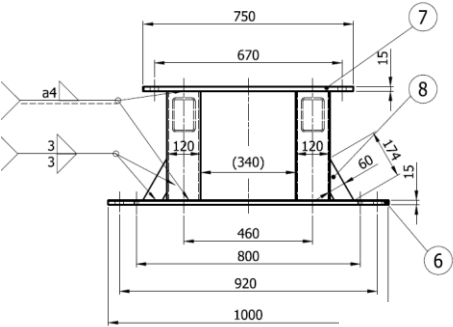

8	FLAT BAR	6	10x60 L=174	S235JRG2
7	PLATE	3	PL 15x140x750	S235JRG2
6	PLATE	3	PL 15x140x1000	S235JRG2
5	RHS-BEAM	4	60x60x5 L=450	S355J2G3
4	RHS-BEAM	4	120x80x5 L=2180	S355J2G3
3	RHS-BEAM	2	120x120x5 L=H6	S355J2G3
2	RHS-BEAM	2	120x120x5 L=H4	S355J2G3
1	RHS-BEAM	2	120x120x5 L=H2	S355J2G3
POS.	CODE	PCS	NAME	MATERIAL

3.2. Konstrukcja bazy uszczelnienia końcowego linia A – 1 szt.

MODEL DRAWING

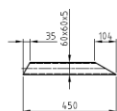
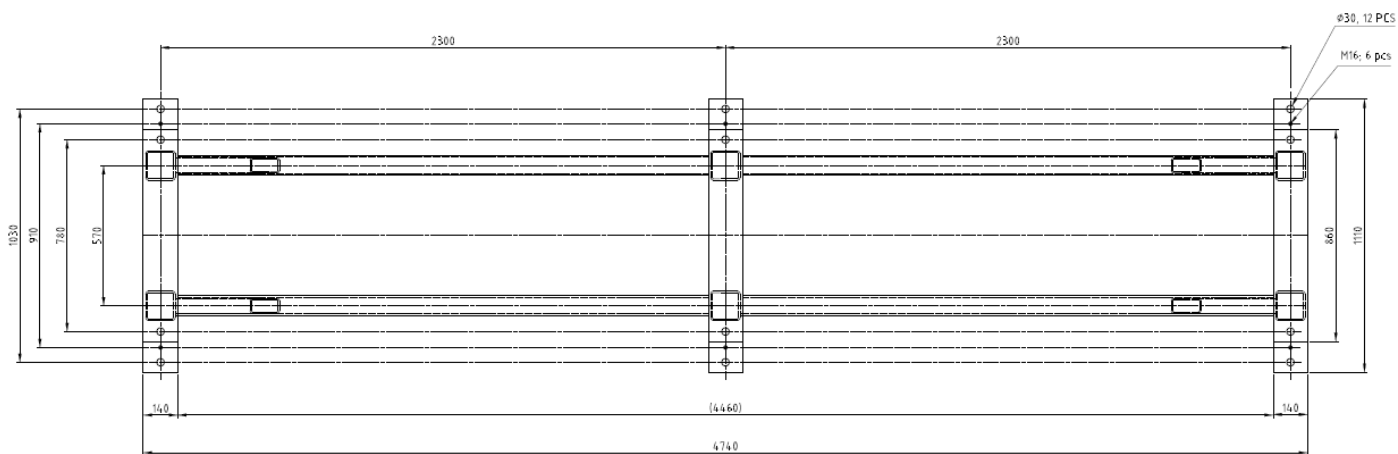
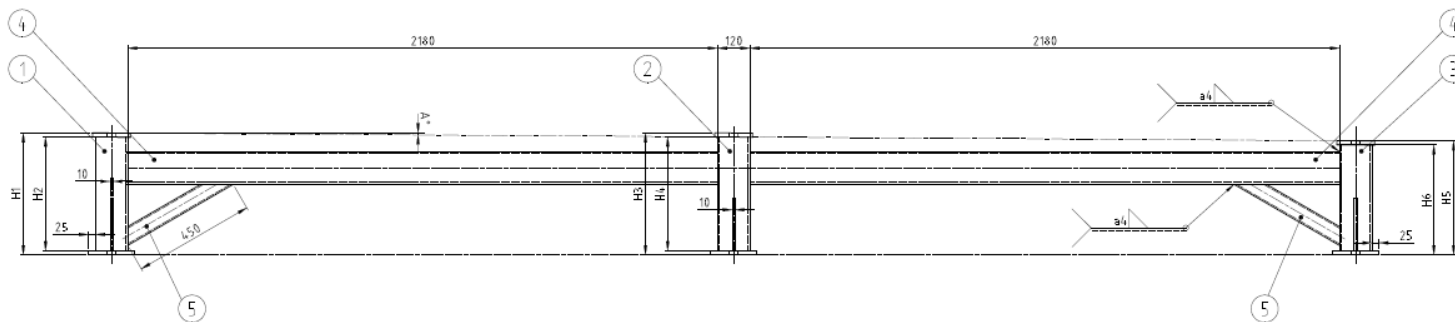
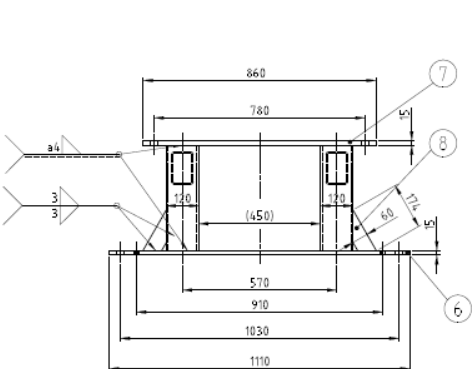

POS. 5

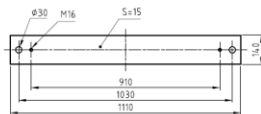

POS. 6

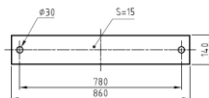

POS. 7

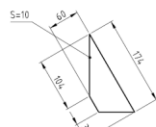

POS. 8

8	FLAT BAR	6	10x60 L=174	S235JRG2
7	PLATE	3	PL 15x140x860	S235JRG2
6	PLATE	3	PL 15x140x1100	S235JRG2
5	RHS-BEAM	4	60x60x5 L=450	S355J2G3
4	RHS-BEAM	4	120x80x5 L=2180	S355J2G3
3	RHS-BEAM	2	120x120x5 L=H6	S355J2G3
2	RHS-BEAM	2	120x120x5 L=H4	S355J2G3
1	RHS-BEAM	2	120x120x5 L=H2	S355J2G3
POS.	CODE	PCS	NAME	MATERIAL

3.3. Wspornik typ A – 2 szt.

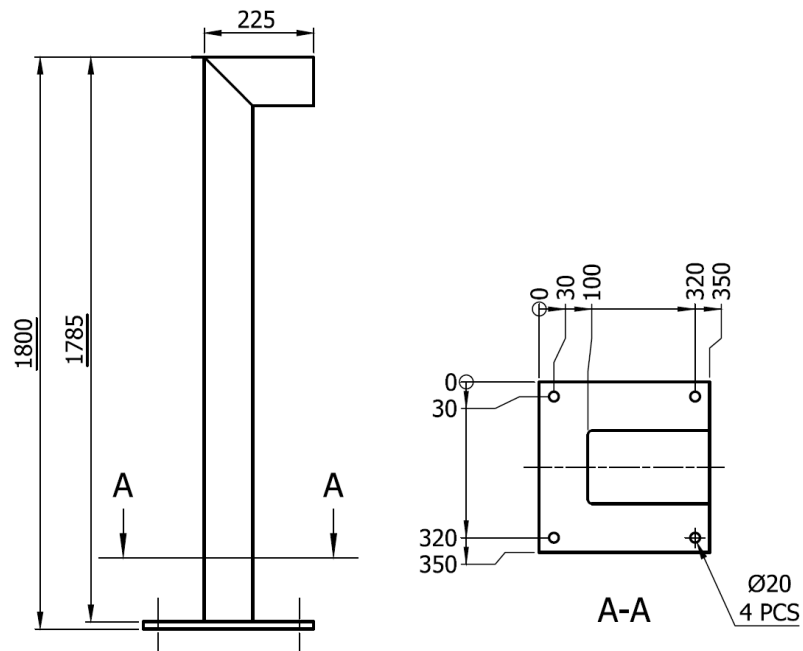

WELDING: 4 mm

WEIGHT: 38 kg

4	CR409919	4	ANCHOR BOLT HSL-3 M12/25	
3		1	PLATE 15x350x350	S235JRG2
2		1	SHS 100x100x4 ...225	S355J2H
1		1	SHS 100x100x4 ...1785	S355J2H
POS	-	PCS	-	MATERIAL

UWAGA!

Po spawaniu zabezpieczyć antykorozyjnie przez malowanie.

3.4. Wspornik typ B – 2 szt.

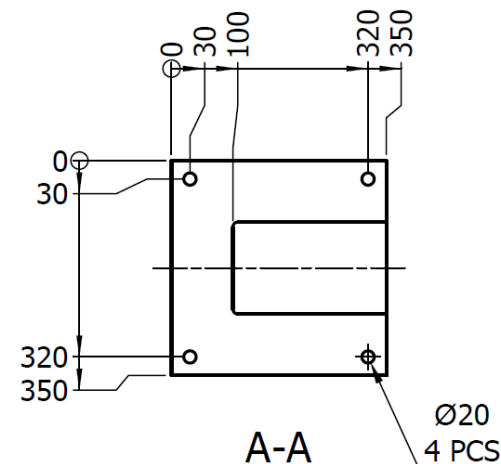
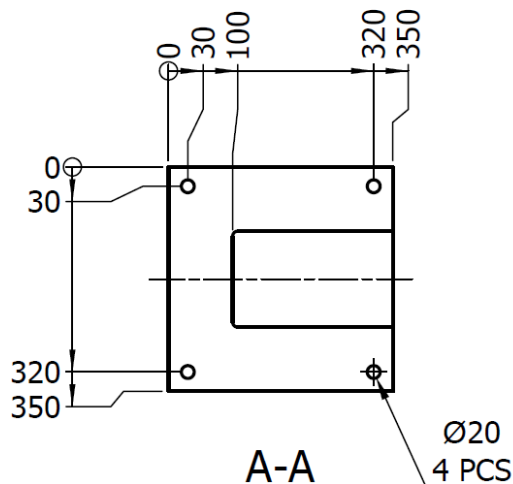
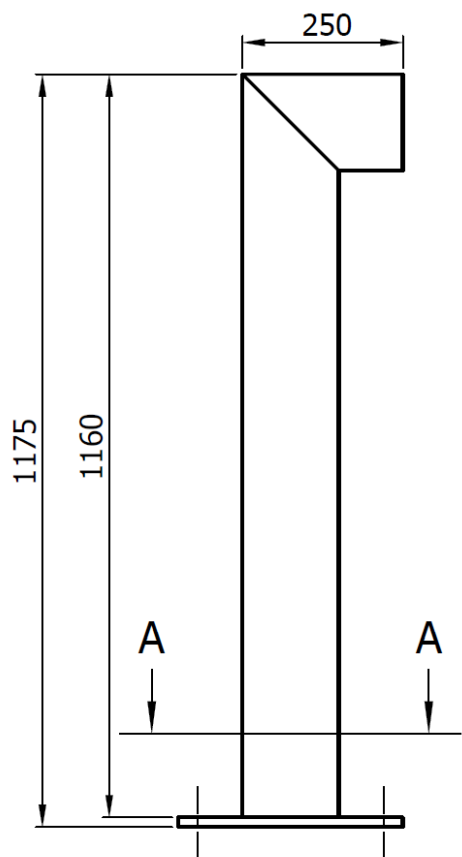

UWAGA!
Po spawaniu zabezpieczyć antykorozyjnie przez malowanie.

3	1	PLATE 15x350x350	S235JRG2
2	1	SHS 150x150x4 ...250	S355J2H
1	1	SHS 150x150x4 ...1160	S355J2H
POS	-	PCS	-
			MATERIAL

3.5. Uszczelka gumowa linia D – 1 szt.

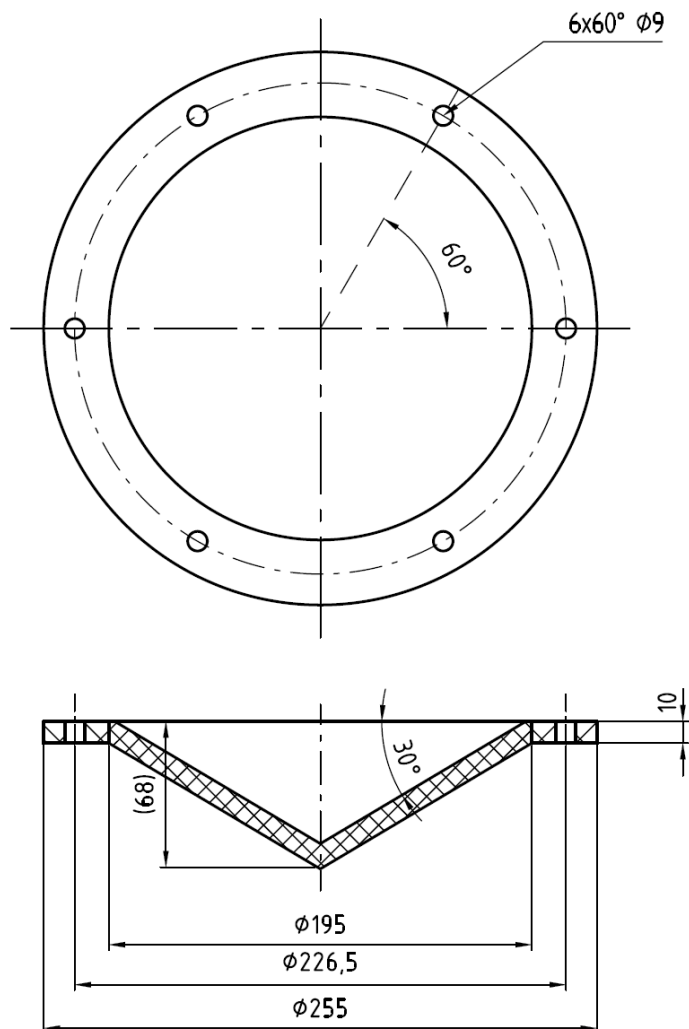

UWAGA!

MATERIAL

SILICONE RUBBER, HARDNESS SHORE 60-70

3.6. Uszczelka gumowa linia A – 1 szt.

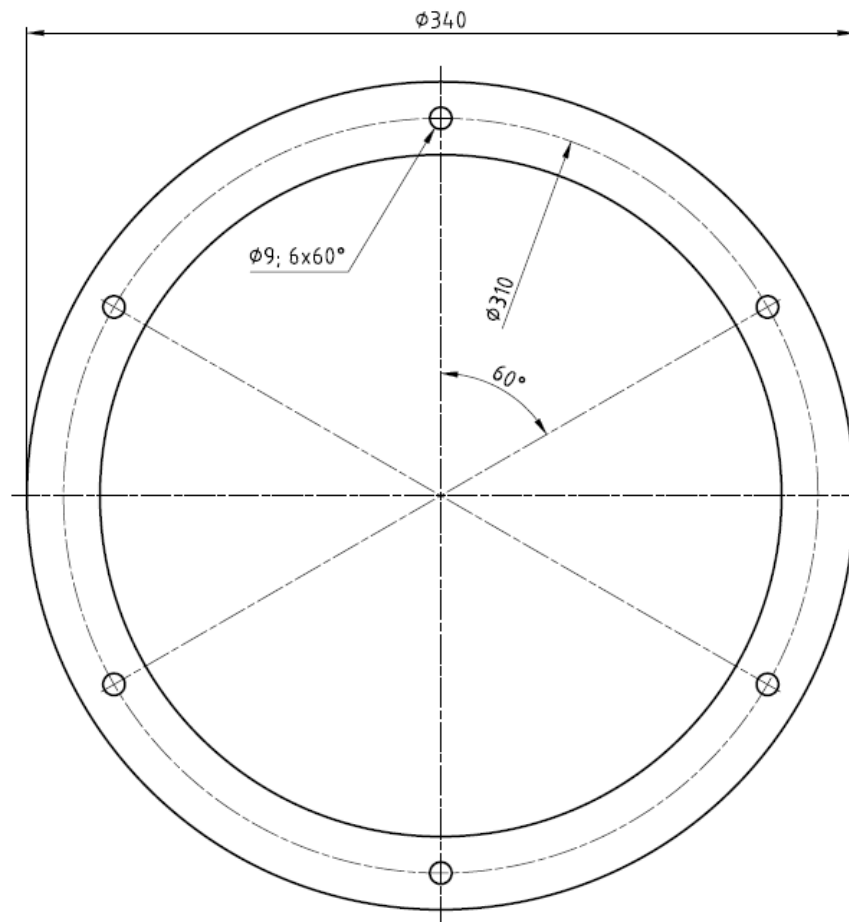
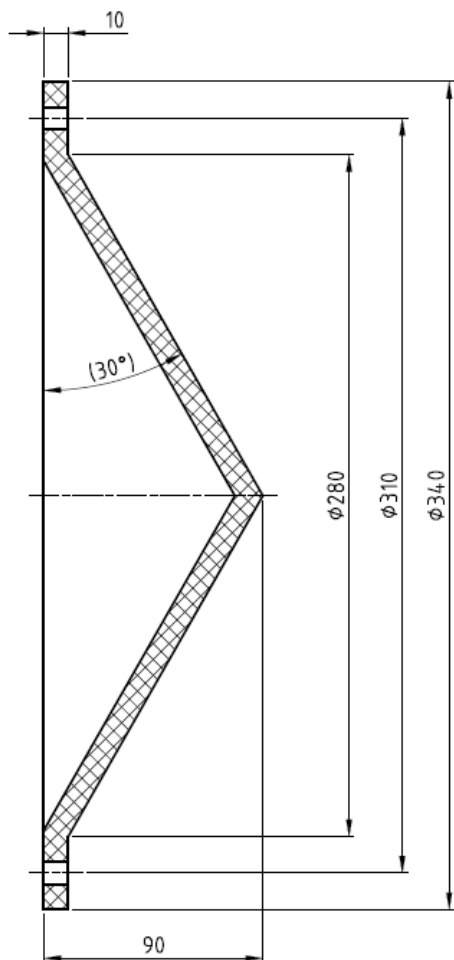

MATERIAL

SILICONE RUBBER, HARDNESS SHORE 60-70

3.7. Podkonstrukcja separatora wody 2szt. (1x linia A, 1 x linia D)

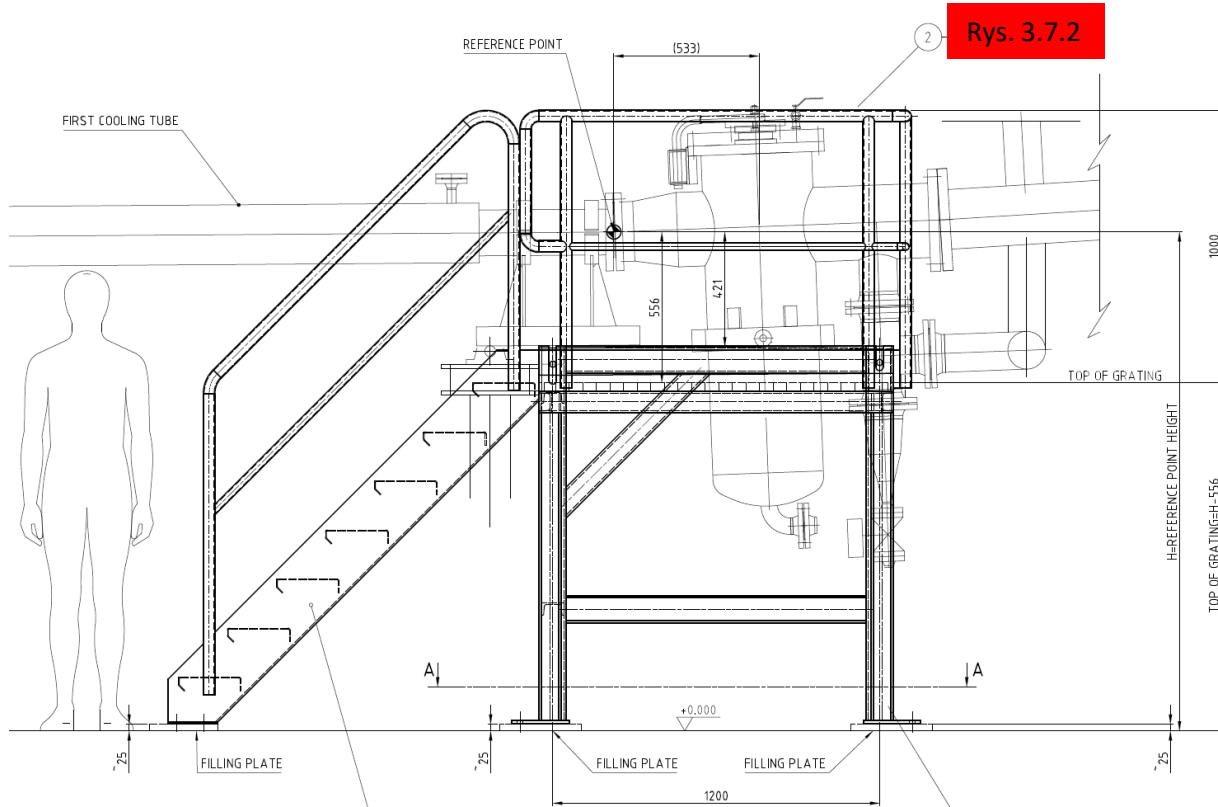

Rys. 3.7.2

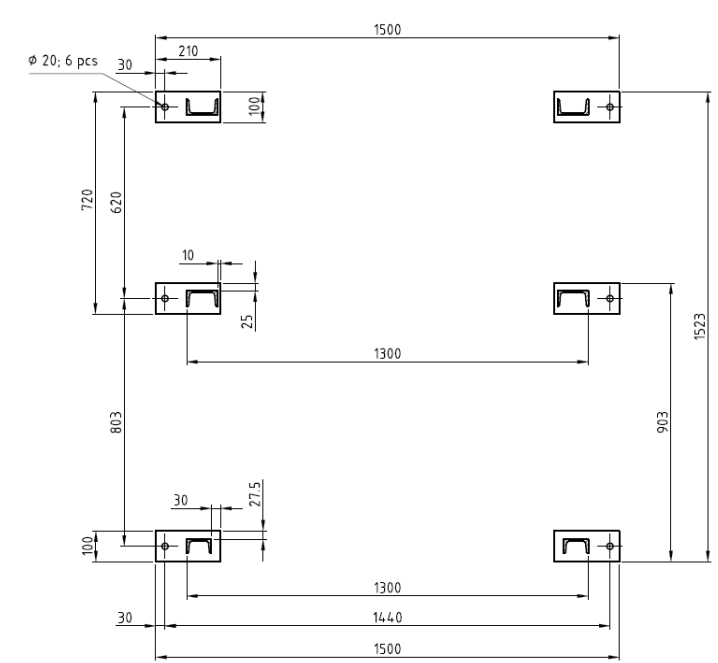

A - A



Rys. 3.7.3

Rys. 3.7.1

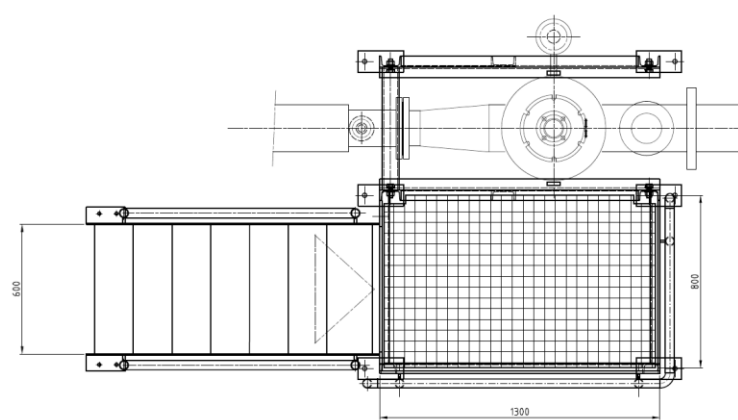

3.7.1. Konstrukcja ramy nośnej

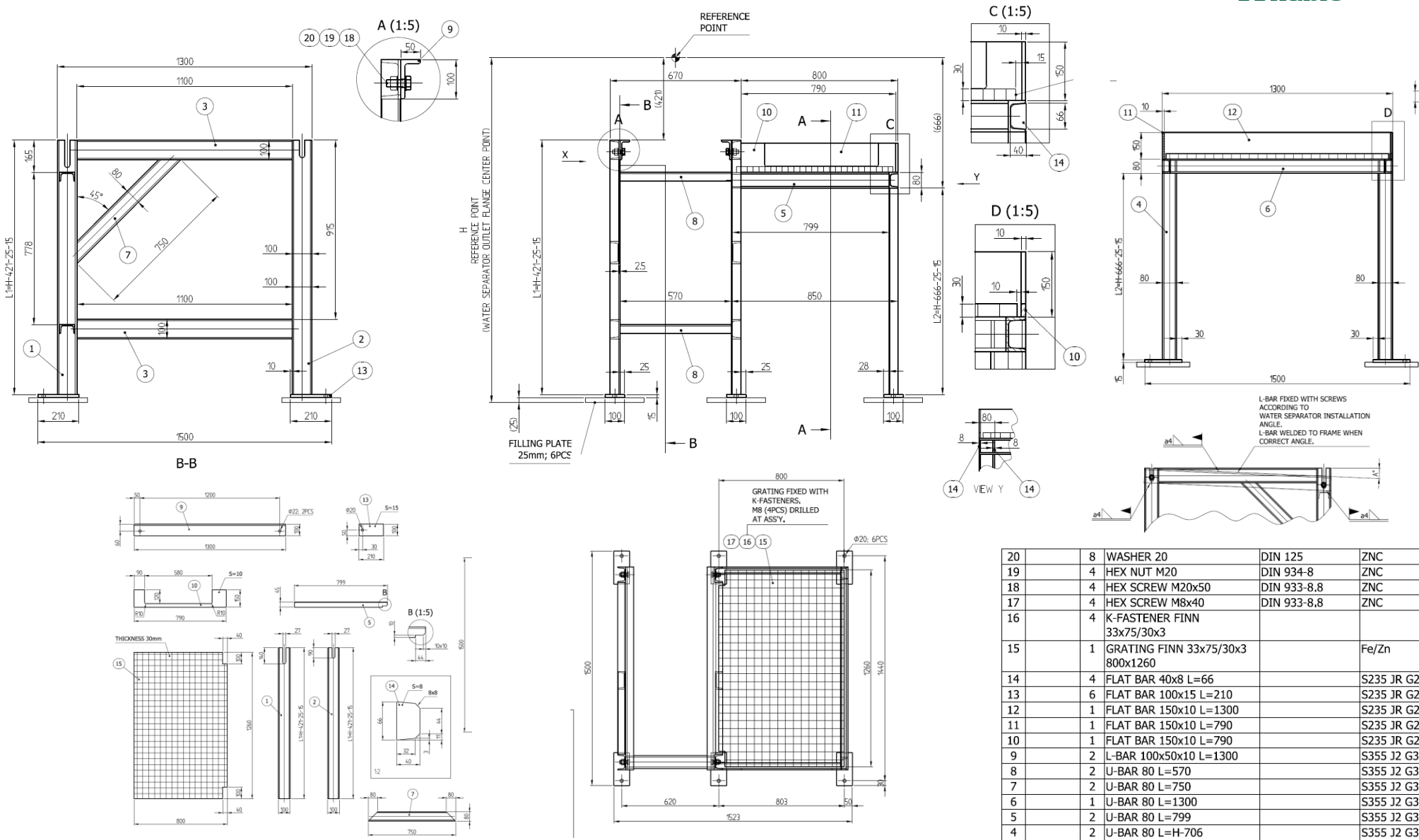

20	8	WASHER 20	DIN 125	ZNC	
19	4	HEX NUT M20	DIN 934-8	ZNC	
18	4	HEX SCREW M20x50	DIN 933-8,8	ZNC	
17	4	HEX SCREW M8x40	DIN 933-8,8	ZNC	
16	4	K-FASTENER FINN 33x75/30x3			
15	1	GRATING FINN 33x75/30x3 800x1260		Fe/Zn	
14	4	FLAT BAR 40x8 L=66		S235 JR G2	
13	6	FLAT BAR 100x15 L=210		S235 JR G2	
12	1	FLAT BAR 150x10 L=1300		S235 JR G2	
11	1	FLAT BAR 150x10 L=790		S235 JR G2	
10	1	FLAT BAR 150x10 L=790		S235 JR G2	
9	2	L-BAR 100x50x10 L=1300		S355 J2 G3	
8	2	U-BAR 80 L=570		S355 J2 G3	
7	2	U-BAR 80 L=750		S355 J2 G3	
6	1	U-BAR 80 L=1300		S355 J2 G3	
5	2	U-BAR 80 L=799		S355 J2 G3	
4	2	U-BAR 80 L=H-706		S355 J2 G3	
3	4	U-BAR 100 L=1100		S355 J2 G3	
2	2	U-BAR 100 L=H-461		S355 J2 G3	
1	2	U-BAR 100 L=H-461		S355 J2 G3	
Ite m	Code	Qty	Description	Standard	Material

3.7.3. Poręczce

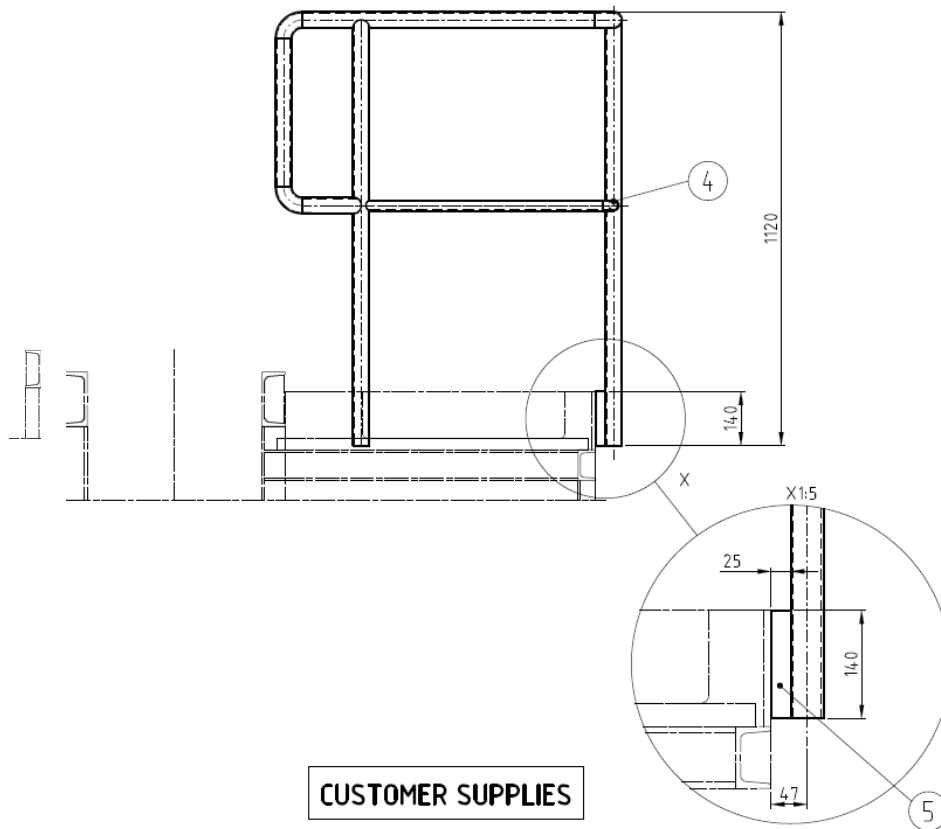
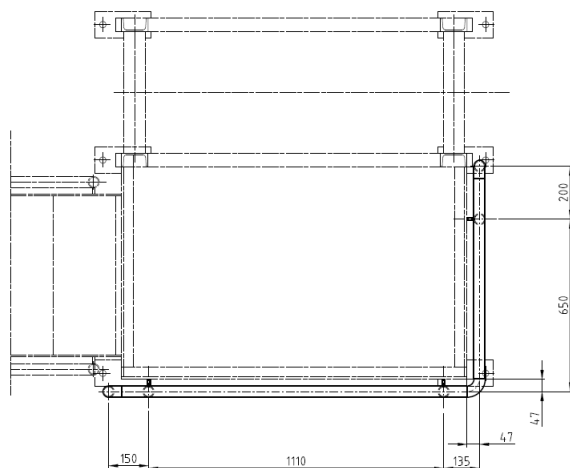
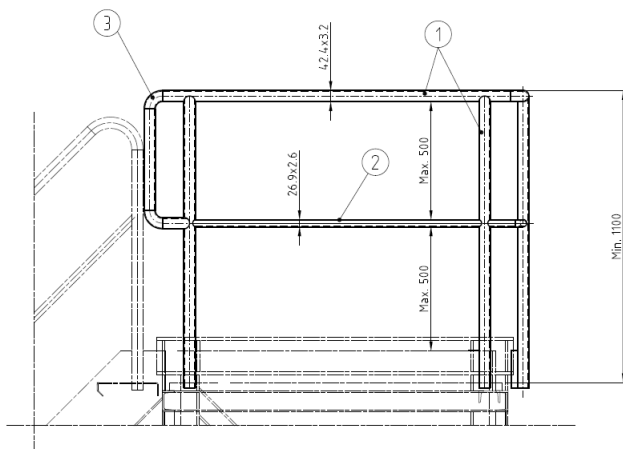

CUSTOMER SUPPLIES

WELDING IF NOT OTHERWISE SHOWN

5		3	LATTATANKO / FLAT BAR	S235JRG2 10x25 L= 140
4		1	PUTKIKÄYRÄ / PIPE CURVE	S235J2G3 90°-26.9x2,6
3		5	PUTKIKÄYRÄ / PIPE CURVE	S235J2G3 90°-42.4x3.2
2			PUTKI / PIPE	S235J2G3 Ø26,9x2,6 ~ 2 M
1			PUTKI / PIPE	S235J2G3 Ø42.4x3.2 ~ 7 M
POS	CODE	PCS	NAME	TYPE

TF Kable

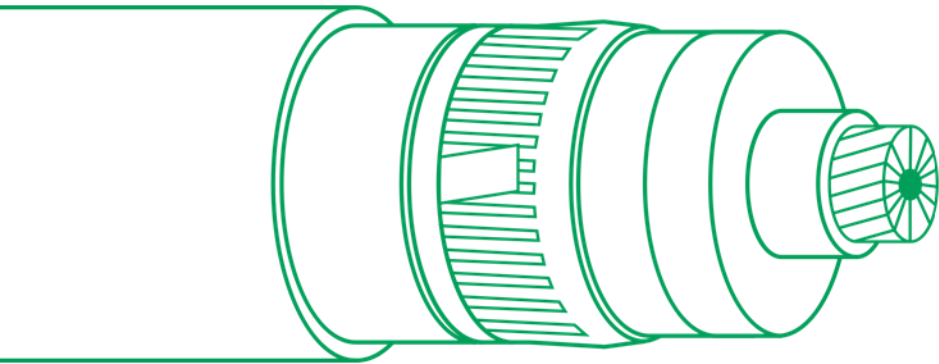

Dziękujemy za uwagę

kontakt:

Piotr Zakrzewski
piotr.zakrzewski@tfkable.com
+48 665 811 613

Zakład TF05 – Bydgoszcz
Ul. Fordońska 152

TELE-FONIKA Kable S.A.
ul. Cegielskiego 1, 32-400 Myślenice
www.tfkable.com

member of the association  **europacable**