

OPERATION AND MAINTENANCE MANUAL

SERVO HYDRAULIC ACTUATOR FOR SMALLER TURBINE EXTRACTION VALVE

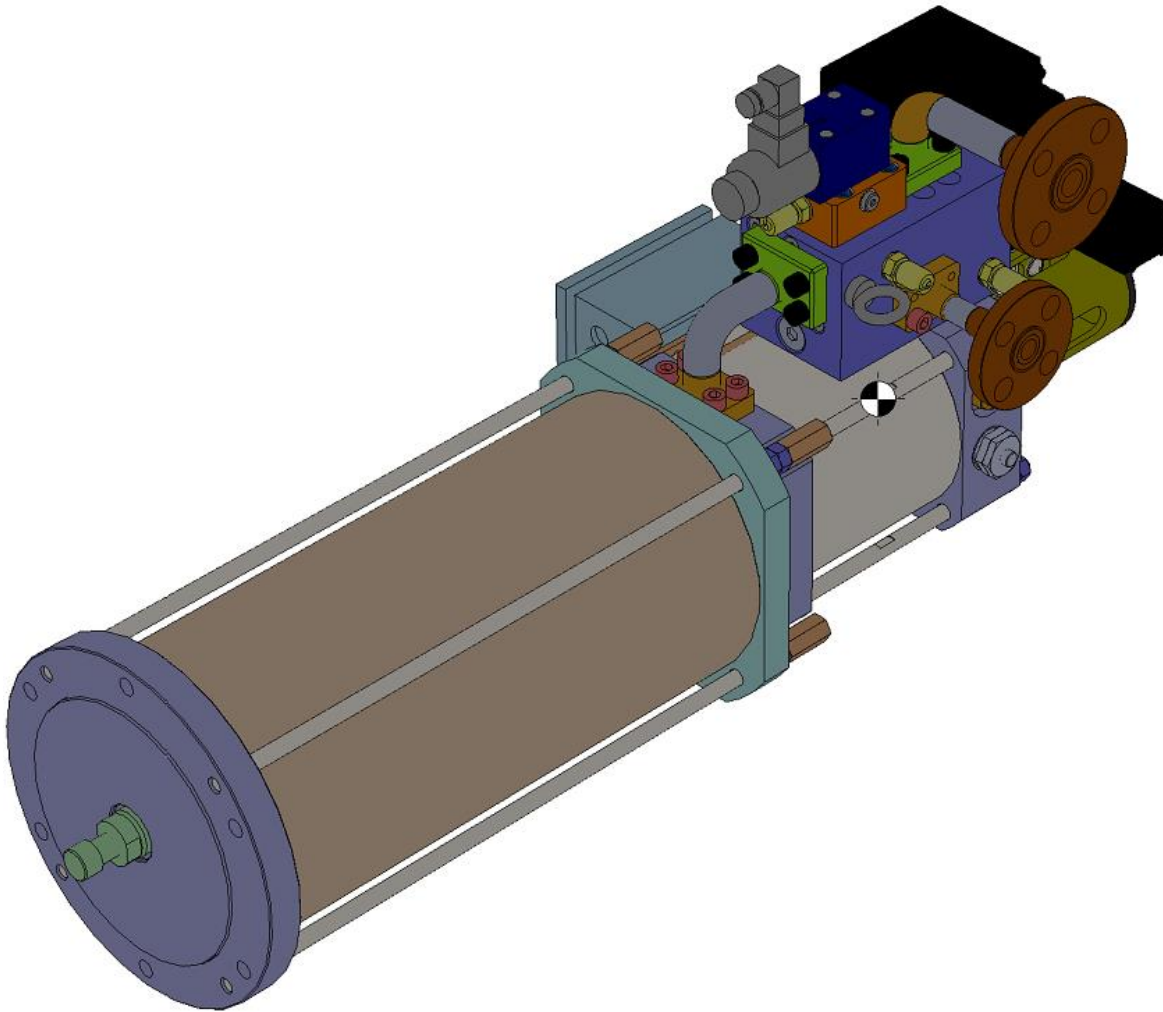

CUSTOMER	:	TRIVENI TURBINE LTD
PROJECT	:	Zarmen Poland
DOCUMENT REF NO.	:	-
TRIVENI P/N	:	BT0233032
MOOG P/N	:	CC66394
REV No.	:	Rev 0

CAUTION: DISASSEMBLY, MAINTENANCE, OR REPAIR OTHER THAN IN ACCORDANCE WITH THE INSTRUCTIONS HEREIN OR OTHER SPECIFIC WRITTEN DIRECTIONS FROM MOOG MOTION CONTROLS PVT. LTD., WILL INVALIDATE MOOG MOTION CONTROL PVT. LTD'S OBLIGATIONS UNDER THE WARRANTY. REFER TO THE MOOG MOTION CONTROL PVT. LTD., WARRANTY FOR COMPLETE PROVISIONS THEREOF.

REVISION RECORD

Rev	Prepared By	Approved By	Description of Revision	Date
0	Muttu/Jowin	Arul	Original Issue	29-Jun-2019

TABLE OF CONTENTS

1.0 INTRODUCTION	8
2.0 ACTUATOR FUNCTIONAL OVERVIEW	9
3.0 ACTUATOR THEORY AND OPERATION	13
3.1 INSTALLATION PREPARATION.....	13
3.2 GENERAL DESCRIPTION AND OPERATION	13
3.3 POSITION TRANSDUCER ASSEMBLY	13
3.4 CYLINDER CONTROL MANIFOLD BLOCK ASSEMBLY.....	13
3.5 SEALING ELEMENTS	14
3.6 OPERATING PRINCIPLE	15
3.7 INSTALLATION DRAWING	17
3.8 ACTUATOR WIRING DIAGRAM.....	18
4.0 SERVO AMPLIFIER CONTROLLER	19
4.1 GENERAL FEATURES	19
4.2 SERVO AMPLIFIER PART NUMBER	19
4.3 CONTROLLER THEORY AND OPERATION	19
5.0 ACTUATOR MAINTENANCE	20
5.1 GENERAL MAINTENANCE GUIDELINES	20
5.2 INSTALLATION OF SEALS	20
5.3 STEPWISE PROCEDURE OF ACTUATOR ASSEMBLY	22
5.4 ACTUATOR DISMANTLING.....	23
5.5 RECOMMENDED PREVENTATIVE MAINTENANCE GUIDELINES.....	24
5.6 CONTAMINATION CONTROL	25
5.7 CALIBRATION REFERENCE	27
5.8 RECOMMENDED SPARES	28
5.9 TIGHTENING TORQUE	28
6.0 ACTUATOR TROUBLE SHOOTING - POSSIBLE CAUSES AND REMEDIES	29
6.1 NO RESPONSE FROM THE ACTUATOR.....	29
6.2 EXTERNAL LEAKAGES FROM ACTUATOR	29
6.3 THE CONTROL OIL INLET PRESSURE DROPS WHEN GOVERNOR COMMAND IS GIVEN	29
6.4 ABNORMAL NOISE FROM THE ACTUATOR	30
6.5 WIRE BREAK DETECTION NOT WORKING	30
6.6 SYSTEM OPERATES ERRATICALLY	30
7.0 ANNEXURE DOCUMENTS	30

LIST OF FIGURES

FIGURE 1 : EXPLODED VIEW OF ACTUATOR.....	8
FIGURE 2 : HYDRAULIC ACTUATOR	9
FIGURE 3 : D634 SERVO VALVE.....	10
FIGURE 4 : MANIFOLD ASSEMBLY	11
FIGURE 5 : PRINCIPLE OF NORMAL WORKING	15
FIGURE 6 : PRINCIPLE OF EMERGENCY MODE	16
FIGURE 7 : ACTUATOR INSTALLATION DRAWING.....	17
FIGURE 8: WIRING DIAGRAM.....	18
FIGURE 9 : INSTALLATION OF SEALS.....	21
FIGURE 10 : KIDNEY-SHAPED DEFORMATION OF THE SEAL RING	21
FIGURE 11 : INSERTING THE SEAL RING INTO THE CLOSED GROOVE.....	21
FIGURE 12 : INSERTING THE SEAL RING INTO THE CLOSED GROOVE.....	22
FIGURE 13 : ASSEMBLY OF HYDRAULIC CYLINDER SIDE	22
FIGURE 14 : SPRINGS IN ACTUATOR.....	22
FIGURE 15 : ASSEMBLY.....	23
FIGURE 16 : FINAL ASSEMBLY	23

TABLES

TABLE 1 : ISO CLEANLINESS CODE	26
TABLE 2 : RECOMMENDED SPARES.....	28
TABLE 3 : TIGHTENING TORQUES	28

WARNINGS AND CAUTIONS



WARNING: This symbol is intended to alert the user to the presence of important operating and maintenance (servicing) instructions and concerning a potential hazard for people in the literature accompanying the product. Failure to comply with these safety instructions can result in serious damage to health and can even prove fatal in extreme cases.



This symbol is intended to alert the user to the presence of uninsulated “dangerous voltage” within the product’s enclosure that may be of enough magnitude to constitute a risk of electric shock to persons.



CAUTION: The symbol and the word “CAUTION” are used to call attention to instructions concerning potential damage to the equipment or to the system.



NOTE: Notes contain useful information for the operator when starting up and operating the equipment or system.

GENERAL INTRODUCTION

The Moog Hydraulic Servo Actuator involves the interface of electronics, hydraulics, mechanics and computer technology. This manual outlines the procedures required for system installation, operation, and scheduled maintenance.

Included with the Moog actuator is an Operation & Maintenance Manual, which includes an installation drawing. This drawing contains important information necessary for actuator installation. To avoid damage to facility and actuator, do not attempt installation or operation without this drawing. If the installation drawing was not received with the actuator, contact Moog to obtain a copy of this drawing.

It is the responsibility of the end-user of the Moog actuator to ensure that under no circumstances, shall the forces placed upon the Moog actuator exceed the specifications given in the installation drawing.

Under no circumstances should an operator attempt to operate the actuator without training and full understanding of system operation. Should there be any questions regarding the information presented herein personnel should contact Moog for clarification.

GENERAL SAFETY PRECAUTIONS

The Hydraulic Servo Actuator is potentially hazardous.

This Steam turbine system involves inherent hazards from high forces, rapid motions and stored energy. You must be aware of all moving and operating components that are potentially hazardous, particularly the actuator in a servo hydraulic system.

Whenever you consider that safety is compromised, press the Emergency Stop button to stop the test and isolate the system from hydraulic or electrical power.

Carefully read all relevant manuals and observe all Warnings and Cautions. The term Warning is used where a hazard may lead to injury or death. The term Caution is used where a hazard may lead to damage to equipment or to loss of data.

Ensure that the operation set-up and the actual function you will be using on materials, assemblies or structures constitute no hazard to yourself or others. Make full use of all mechanical and electronic limit features. These are supplied to enable you to prevent movement of the actuator piston or the moving crosshead beyond desired regions of operation. Limits provide protection for your machine and reduce potential hazard.

The following pages detail various general warnings that you must always heed while using the equipment. You will find more specific Warnings and Cautions in the text whenever a potential hazard exists.

Your best safety precautions are to obtain training in the operation of equipment that you are using and to read your Operating Instructions and Reference Manual(s) to gain a thorough understanding of that equipment.

GENERAL WARNINGS



Set the appropriate limits before performing loop tuning or running waveforms or tests.

Limits are included within your system to provide a safe way of limiting actuator movement. Failure to set these limits appropriately could result in injury to personnel or damage to equipment.



Actuators may move beyond their nominal stroke under some operating conditions.

Due to the inherent design of servo-hydraulic actuators, sudden movement beyond the nominal stroke of the actuator may be possible, should the closed-loop control become unstable. This may be due to inappropriate gain settings or other changes to the control loop.



Disconnect the electrical power supply before removing the covers to electrical equipment.

Disconnect equipment from the electrical power supply before removing any electrical safety covers or replacing fuses. Do not reconnect the power source while the covers are removed. Refit covers as soon as possible.



Disconnect power supplies before removing the covers to rotating machinery.

Disconnect equipment from all power supplies before removing any cover which gives access to rotating machinery. Do not reconnect any power supply while the covers are removed unless you are specifically instructed to do so in the manual. If the equipment needs to be operated to perform maintenance tasks with the covers removed, ensure that all loose clothing, long hair, etc. is tied back. Refit covers as soon as possible.



Shut down the hydraulic power supply and discharge hydraulic pressure before disconnection of any hydraulic fluid coupling.

Do not disconnect any hydraulic coupling without first shutting down the hydraulic power supply and discharging stored pressure to zero. Tie down or otherwise secure all pressurized hoses to prevent movement during system operation and to prevent the hose from whipping about in the event of a rupture.



Shut off the supply of compressed gas and discharge residual gas pressure before you disconnect any compressed gas coupling.

Do not release gas connections without first disconnecting the gas supply and discharging any residual pressure to zero.



Protect electrical cables from damage and inadvertent disconnection.

The loss of controlling and feedback signals that can result from a disconnected or damaged cable causes an open loop condition that may drive the actuator rapidly to its extremes of motion. Protect all electrical cables, particularly transducer cables, from damage. Never route cables across the floor without protection, nor suspend cables overhead under excessive strain. Use padding to avoid chafing where cables are routed around corners or through wall openings.



Take care when installing or removing a specimen, assembly or structure.

Installation or removal of a specimen, assembly or structure involves working inside the hazard area of the motion envelope of the system. Ensure that all actuator movements necessary for installation or removal are slow and, where possible, at a low force setting.

1.0 Introduction

1.1 Purpose

The purpose of this manual is to provide detailed installation and commissioning procedures for the Moog Hydraulic Servo Actuator. Procedures in this manual are outlined to a level approved by the manufacturer, Moog. If any information required beyond the scope of this manual is required, please contact MOOG.

In order to alert the installer or operators to potential hazards and highlight helpful procedures, the following conventions will be used.

1.2 Exploded View

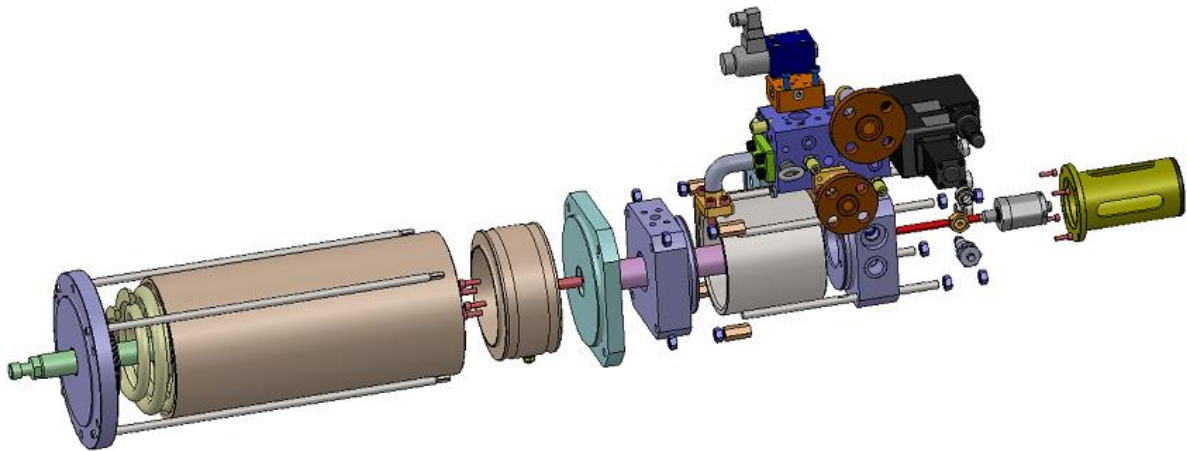

Figure 1 : Exploded view of actuator

1.3 General Features

Type	Single ended actuator with spring to retract the actuator
Seal ratings	10 million fully reversible cycles
Ends	Front End - Flange mounting Rod coupling to connect to mechanical lever of steam valve
Piston rods	High tensile material to ensure long term durability
End Cushions	Hydraulic variable cushion on bore side is provided to prevent impact during emergency retract condition
Actuator Specification	Ø150 Bore x Ø45 Rod - 80mm Stroke, variable Cushion at bore end, 25bar
Triveni Model Number	BT0233032
Moog Model Number	CC66394
Proportional Valve Model Number	D634-1005
PI Amplifier Model Number	G122-829A011
Emergency Solenoid Model Number	X820-21PA-001N01
Position Transducer Model Number	CC51375

2.0 Actuator Functional Overview

2.1 Actuator Overview

The Actuator consists of a hydraulically powered piston which can extend and retract. A Proportional valve controls the actuator precisely and works together with a mechanical position control, which gives a command feedback, and controls piston position always.

Specially designed for Steam Turbine applications, the hydraulic actuator is characterized by low friction, long life, and no external leakage. It includes such features as cushioning at the end of the stroke, direct Proportional valve mounting and a displacement transducer.

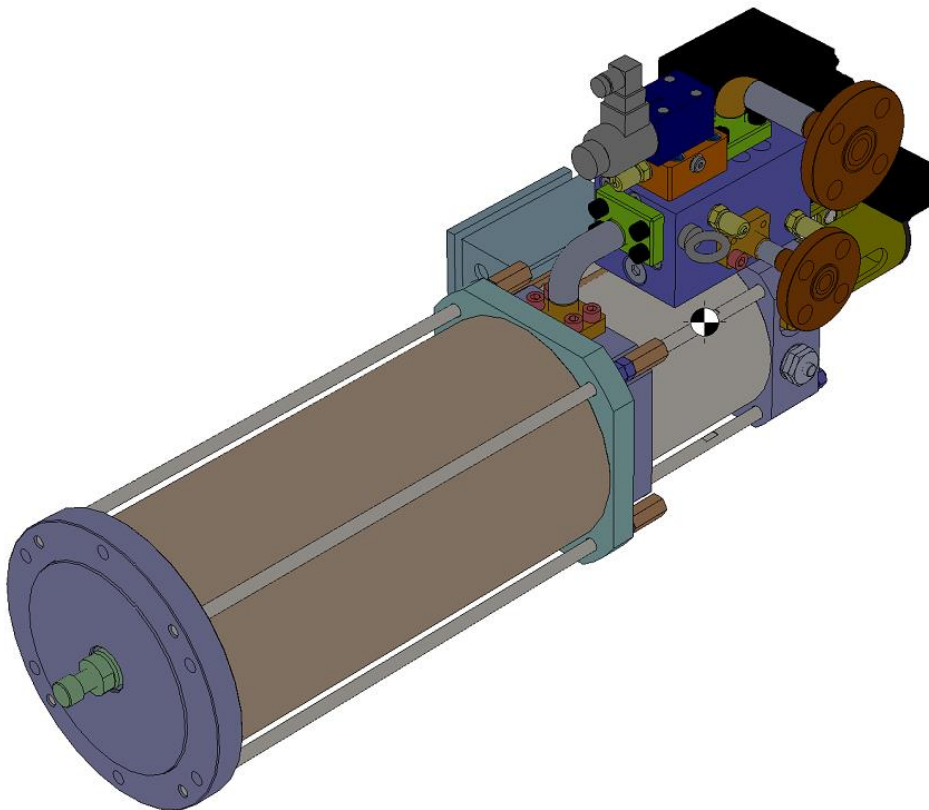

Figure 2 : Hydraulic Actuator

The main components of the steam turbine servo hydraulic actuator are as follows:

Cylinder: The actuator cylinder body is the main structural element and is made from high tensile and high impact strength steel.

Manifold: A manifold is used to mount the hydraulic components, including the Servo-Proportional valve. This manifold includes pressure and return ports for convenient hose attachment.

Cushion: A cushion is at end of travel in retracting direction. This cushion provides a reduction in velocity as the actuator approaches the end of travel at a high rate of speed. The cushion is designed to provide true active adjustable cushioning.

Piston Rod: The piston rod is of a high strength, hard and wear resistant, and moderate ductile steel and has an advanced chrome coating which provides high surface to aid in extending seal life.

Refer to the installation drawing provided with the Moog Hydraulic Actuator for specific installation information

2.2 D634 SERIESSERVOVALVE

The D634-P Series are Direct Drive Valves (DDV) with electric closed loop spool position control. These valves are throttle valves for 3-, 4-, and 2x2-way applications. They are suitable for electrohydraulic position, velocity, pressure and force control systems, including those with high dynamic response requirements.

The spool drive device is a permanent magnet linear force motor which can actively stroke the spool from its spring centred position in both directions. This is an advantage compared with proportional solenoids with one force direction only. The closed loop spool position electronics and pulse width modulated (PWM) drive electronics are integrated into the valve. The integrated electronics of the valves is a new development featuring SMD technology with pulse width modulated (PWM) current output stage and requires a 24 VDC power supply.

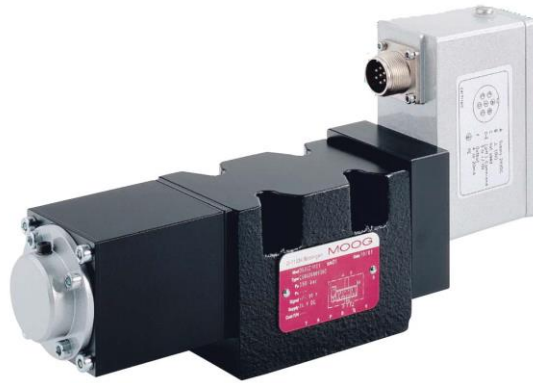

Figure 3 : D634 Servo valve

- Directly driven by a permanent magnet linear force motor with high force level
No pilot oil flow required
- Pressure independent dynamic performance
- Low hysteresis and low threshold.
- Low current consumption at and near hydraulic null
- Increased operation at limits (at high pressure drops)
- Standardized spool position monitoring signal with low residual ripple
- Electric null adjustable
- With loss of supply voltage, a broken cable, or an emergency stop, the spool returns to its spring centred position without passing a load move position
- Please go through the catalogue of D634 series servo valve provided along with this Manual for further details on this product

2.3 Actuator Manifold

The D634 series Proportional valve is mounted on a manifold which mounts directly on the actuator. The manifold is designed such that not much external piping is required on the actuator. The manifold has connections for pressure and return on same sides of the manifold for ease of connection. The manifold houses all the required valves for functional output. Minimes points are provided for measuring pressure at all critical ports.

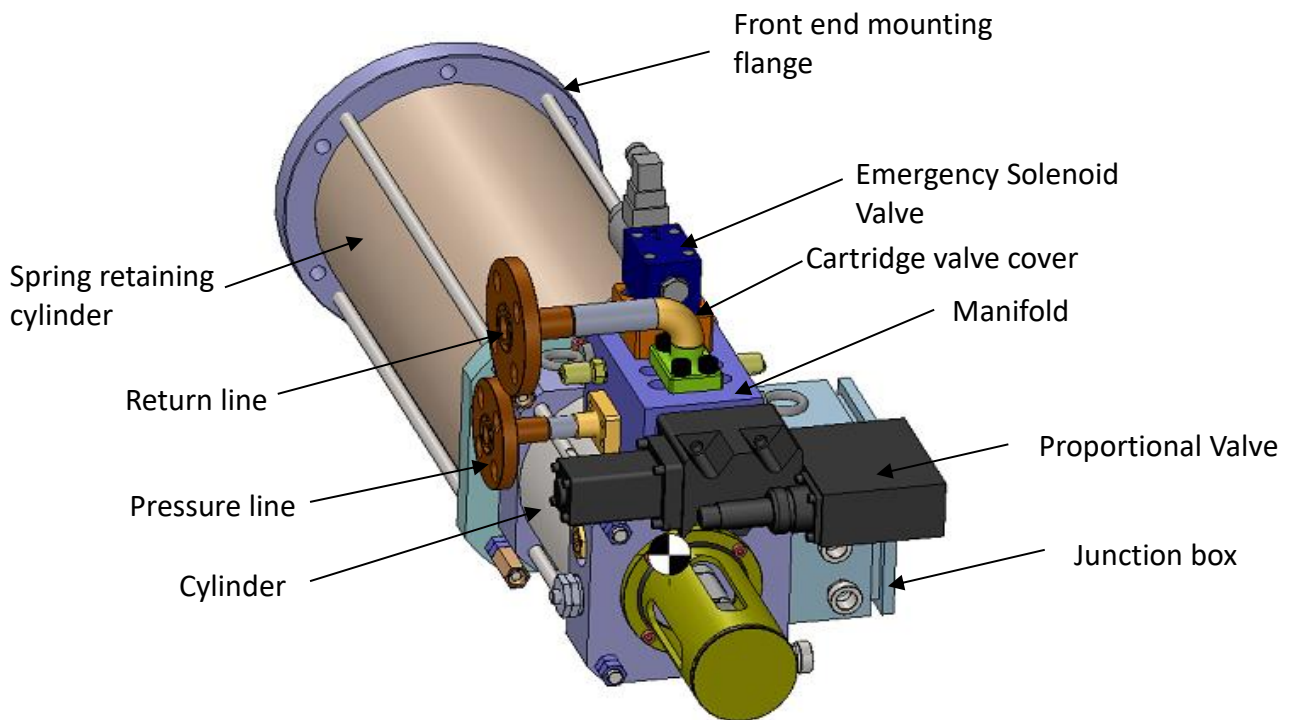

Figure 4 : Manifold Assembly

2.4 ACTUATOR SPECIFICATIONS

Description	Specified Value
Actuator Type	Actuator is single acting
Actuator Bore	∅ 150mm
Actuator Rod	∅ 45mm
Stroke	80mm
Mounting Style	Front Circular Mounting
Cushioning	Bore end variable cushioning
Position monitoring	Contact less displacement transducer
Working Pressure	25bar
Test Pressure	35bar
Emergency closing time	< 5s
Normal Opening	< 10s
Max Force generated	25.3kN (Momentary) @ 25bar when Actuator fully Retracted. 20.0kN @ 25bar when Actuator fully Extended.
Minimum spring force (0% stroke)	14.077kN
Maximum spring force (100% stroke)	19.405kN
Solenoid Voltage	24 VDC
Temperature range	-20°C to +80°C ambient
Fluid	Mineral oil based Hydraulic fluid
Fluid cleanliness	ISO 4406 < 18 / 15 / 13 (NAS 7)
Pressure line connection	ANSI 1/2", Class 300 SS-316L
Tank line connection	ANSI 3/4", Class 300 MS

3.0 Actuator Theory and Operation

3.1 Installation Preparation

- Clear the area surrounding the installation site
- Flush the hydraulic supply lines of foreign material by interconnecting the pressure and return lines around the Hydraulic Actuator assembly. The actuators are clean when shipped from Moog
- Flushing blocks can be used
- Circulate hydraulic fluid through the system at full pump flow
- Replace the system filter elements when indicated by their contamination alarms
- Flush the system until the cleanliness level required (documented in maintenance section) is achieved
- Connect hydraulic supply pressure to P and return to R on the actuator manifold
- Connect the instrument signal cables per the electrical schematic

3.2 General Description and Operation

The cylinder is designed as per customer specifications for steam control application. The Proportional valve mounted on the cylinder manifold assembly is used to control the cylinder stroke with the feedback received from Position Transducer Assembly which is fitted in piston rod. Special cartridge constructed valve and cover is designed to cater the emergency condition required during operation.

- The normal operation is through Proportional valve activation
- Mounting Style of Cylinder is Horizontal on Front Flange

3.3 Position Transducer Assembly

Position Transducer assembly consists of displacement transducer, Floating Magnet which is assembled on the piston Rod by using a spacer. The function of position transducer is to sense the position of the cylinder with the help of Floating Magnet attached with respect to the total stroke and gives the feedback. The required position is achieved by the Proportional Valve. Position Transducer is mounted on Rear Flange of the actuator.

3.4 Cylinder Control Manifold Block Assembly

The cylinder control manifold block assembly consist of Solenoid operated direction control Valve, Proportional Valve and Cartridge Valve Assembly.

The function of this assembly is to control the oil flow in the cylinder to achieve the required stroke with the help of Proportional Valve. The solenoid valve is used to control the Cartridge Valve assembly.

Cartridge valve assembly consists of cartridge block and cover assembly. The solenoid valve is de-energized only during emergency conditions.

[Fig reference available in section 2.2: Manifold assembly]

3.5 Sealing Elements

The sealing elements inside the actuator consist of following sealing and guiding elements:

1. Glyd-Ring
2. Step Seal
3. Wiper
4. Slyd-Ring
5. O-Rings.

3.5.1 Glyd-Ring

The Function of Glyd-ring is to provide a leak free sealing between the bore end and rod end. Glyd-ring is preferred due to following reasons.

- No stick-slip effect when starting for smooth operation of the cylinder
- Minimum static and dynamic friction coefficient for a minimum energy loss and operating temperature
- High wear resistance ensures long service life
- No adhesive effect to the mating surface during long period of inactivity or storage
- Suitable for most hydraulic fluids in relation with most modern hardware materials and surface finish
- Suitable for environmentally safe hydraulic fluids

3.5.2 Step Seal

Rod seals must exhibit no dynamic leakage to the atmosphere side under all operating conditions and must be statically complete leak tight, when the machine is at a standstill. This is achieved due to the hydrodynamic properties of the seal. The specially formed seal edge with a steep contact pressure gradient on the high-pressure side and a shallow contact pressure gradient on the low-pressure side ensures that the fluid film adhering to the piston rod is returned to the high-pressure chamber on the return stroke of the rod. This prevents the micro-fluid layer, carried out of the high-pressure chamber when the piston rod is extended, causing leaks. Step seal is preferred due to following reasons:

- High static and dynamic sealing effect
- Low friction, high efficiency
- Stick-slip-free starting, no sticking
- High abrasion resistance, high operational reliability
- Wide range of application temperatures and high resistance to chemicals
- Simple installation without seal edge deformation

3.5.3 Wiper

Wiper is installed in hydraulic cylinders to wipe any dirt, foreign particles, chips, moisture, etc. from the piston rods as they are retracted into the system, thus preventing contamination of the hydraulic medium which would otherwise damage wear rings, seals and other components. Wiper is preferred due to following reasons:

- Low friction
- Good scraping effect both inwards and outwards
- Simple, small installation groove
- Compact design

3.5.4 Slyd-Ring

The function of Slyd-ring is to guide the piston head of hydraulic cylinder and to absorb the transverse Forces developed due to axial load. Slyd-rings avoid metallic contact between the sliding parts of the cylinder, e.g. piston rod and Seal retainer, Piston Head and Cylinder. Slyd-ring is preferred due to following reasons:

- High load bearing capacity
- Eliminates local stress concentrations
- Wear-resistant, long service lives
- Favourable friction behaviour
- Damping of mechanical vibrations
- Good wiping effect, embedding of foreign particles possible
- Protection of the seal against “dieseling”
- Eliminates hydrodynamic pressure problems in the guide system
- Simple closed groove, easy installation

3.5.5 O-Rings

O-Rings are installed in Hydraulic cylinder and are used as sealing elements or as energizing elements. They are mainly used as static seal for Flanges, Valves, and manifold block sealing.

3.6 Operating Principle

There are two situations in the operating condition of hydraulic actuator.

- Normal working mode
- Emergency mode

3.6.1 Normal Working Mode

MOOG control card (P-I Card) receives the input command from Woodward Governor (4-20mA) and control card accordingly gives command to drive the Proportional Valve D634 mounted on actuator. Based on the valve opening and the inlet flow and pressure, the piston starts to move.

The position transducer inside the actuator gives a feedback to the PI Card. Based on this feedback PI Card controls the opening and closing of the Proportional valve to achieve the required position of the actuator for steam control (i.e. steam control actuator).

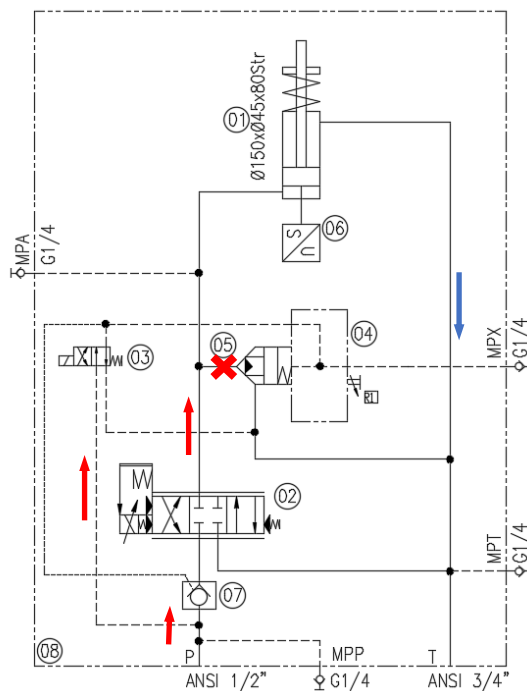

Figure 5: Principle of Normal Working

Operation and Maintenance Manual

In hydraulic terms oil supply from Pump is connected to 'P' port on actuator which is an input flow to the Proportional valve. The Proportional valve opening, and closing is controlled by PI card.

- Solenoid valve (03) is always in ON condition
- Pilot line taken from main pressure line closes the cartridge valve (05) when solenoid valve is in ON condition
- P->A & B->T can be achieved by giving 12->20 mA command to Proportional valve
- P->B & A->T can be achieved by giving 12->4 mA command to Proportional valve
- Normal working mode is basically "Position closed-loop"
- Depending on the demand from governor, Proportional valve will get relative command signal to keep the actuator at required position
- When actuator needs to Extend to open steam valve, 12->20 mA command would go to Proportional valve. Proportional valve position will be P->A & B->T. Pressurized oil will go to actuator's Bore area to Extend it
- When actuator needs to retract to close steam valve, 12->4 mA command would go to Proportional valve. Proportional valve position will be P->B & A->T. Spring inside actuator will pull piston backward and oil will be drained from A->T.

3.6.2 Emergency Mode

Operational Features of the Complete Valve

- Valve body for high rated flow, optional with external pilot supply using X and Y ports.
- Failsafe versions available with defined safe spool position.
- The D634 series proportional control valves are of two-stage design.
- By combining a fast first stage, suitable main spool drive area and integrated electronics, an optimum proportional valve is offered.

Please go through the catalogue D634 series Proportional valves with Integrated Digital Electronics catalogue provided along with this Manual for further details on this product.

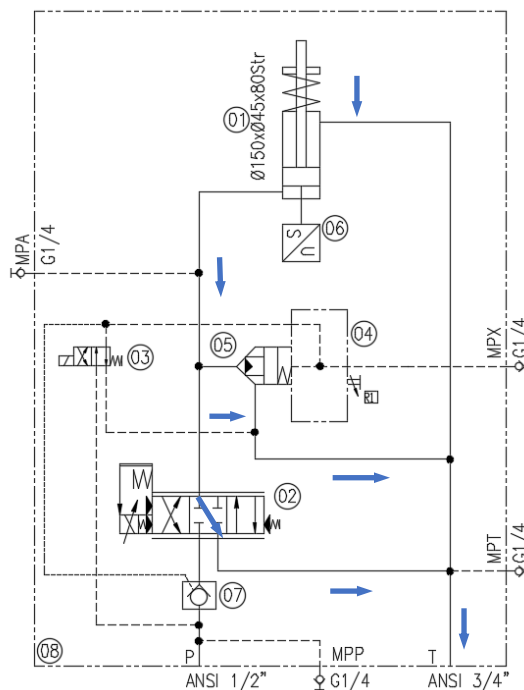

Figure 6: Principle of Emergency mode

3.8 Actuator Wiring Diagram

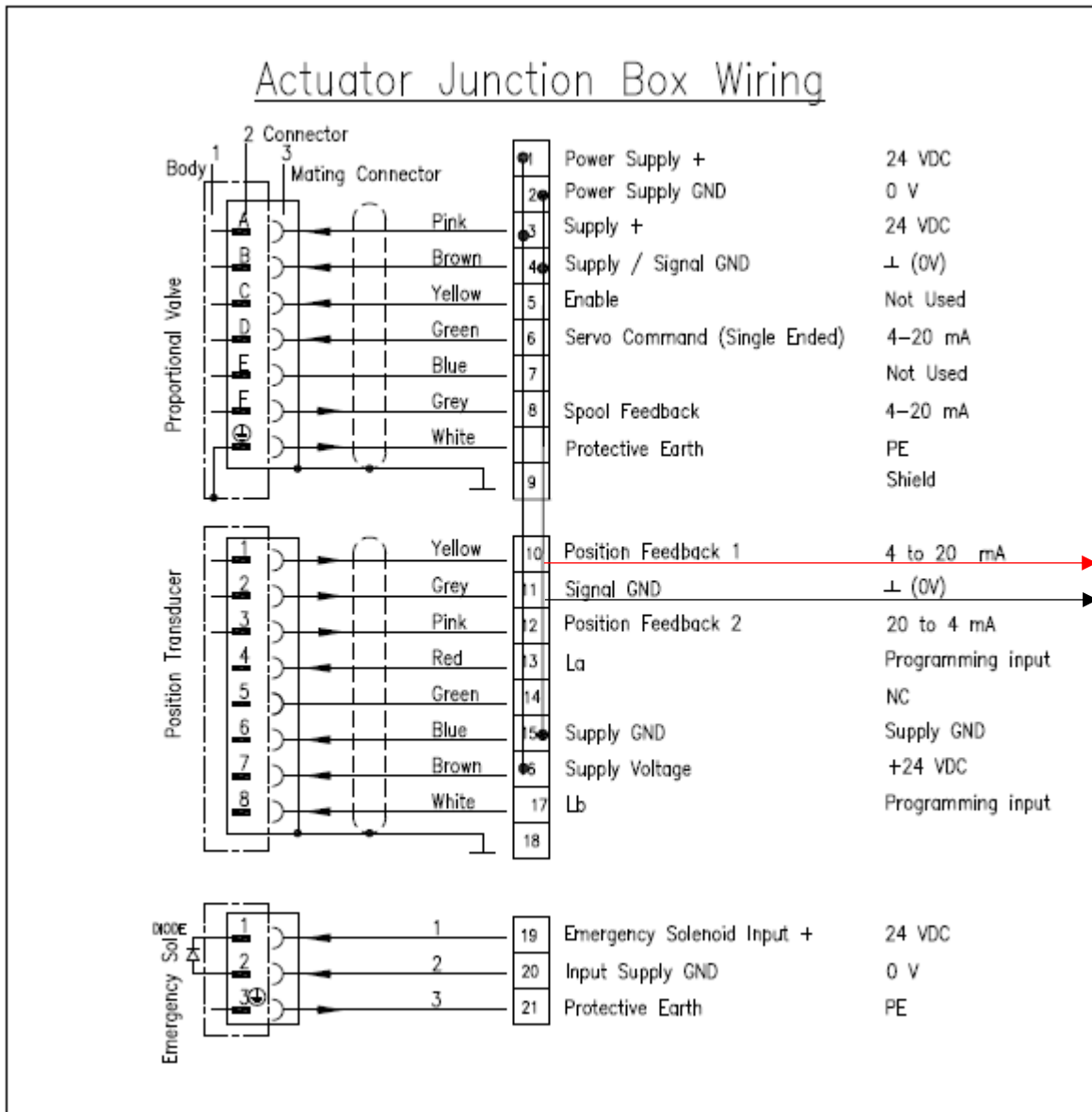

Figure 8: Wiring Diagram

4.0 Servo Amplifier Controller

4.1 General Features

- P, I or P & I control
- User friendly front panel with LEDs and test points
- Single ended input, 4-20 mA or ± 10 V, switch selectable
- Single ended input, scalable
- Differential input with zero and gain
- Feedback transducer excitation output
- Step push button
- Optional feedback derivative term
- IN POSITION output
- Dither
- Enable input
- Compact DIN rail housing
- CE marked

4.2 Servo Amplifier Part number

The following part number is supplied to Triveni Turbine Ltd:

G122-829-A011

4.3 Controller Theory and Operation

The G122-829-A011 P-I Servo amplifier is used in closed loop applications where a proportional AND/OR integral amplifier is needed. Selector switches inside the amplifier enable proportional, integral or both to be selected. Many aspects of the amplifier's characteristics can be selected with internal switches. This enables one amplifier to be used in many different applications. The configuration options that are provided is a result of many years of expertise in designing and commissioning closed loop systems.

The Servo amplifier employs analogue electronics. It accepts three input signals, two single ended and one differential. These are summed to produce an error signal which is then amplified proportionally and integrated. The proportional and integral signals are switched together and output as a current or voltage to drive a servo or proportional valve.

Front panel trim pots, LED indicators and test points allow fast and easy setup and aid in trouble shooting. The servo amplifier is housed in a compact DIN rail mounting enclosure and requires a +24V supply.

5.0 Actuator Maintenance

5.1 General Maintenance Guidelines

Perform regular maintenance on the actuator for the following reasons:

- Safety of personnel
- Longest possible time to prepare for component failure due to wear
- Cost Savings

5.1.1 Qualified Personnel

- Maintenance and repair of the actuator must be carried out by qualified technical personnel ONLY
- Technical personnel must have all knowledge and training regarding safety precautions and operation of the equipment

5.1.2 Precautions

Before starting any repair or Maintenance ensure the following:

- Safety conditions fulfilled
- Power turned off to the system
- Pressure has been discharged from the accumulators



Only original Moog spare parts may be used in the Moog Hydraulic Actuator. If non-authorized parts are used, Moog will not accept liability for possible consequential damages.

5.2 Installation of Seals

Seals are the most important elements responsible for performance and leak free holding of the cylinder. Direction of installation of some of the seals is critical from functioning point of view. One should refer to the cylinder cross-section drawing before installation. The seals catalogue gives details of installation, precautions and loading tools required. Improper installation of seals may damage the seals and cylinder parts while installation which in turn will damage the whole actuator

5.2.1 Piston Seals

The loading mandrels are used to load seals on piston head. The O-Ring is first loaded in the piston groove. The outer ring is harder and not elastic enough to stretch easily on the groove. The outer ring can be stretched and mounted over the groove or can be installed using the loading mandrel. In both the cases the outer dimensions of the seal change and increase beyond the nominal bore size. The outer ring needs to be resized after installing. The resizing is done either using the sizing tool or the cylinder body itself as shown in figure 8.

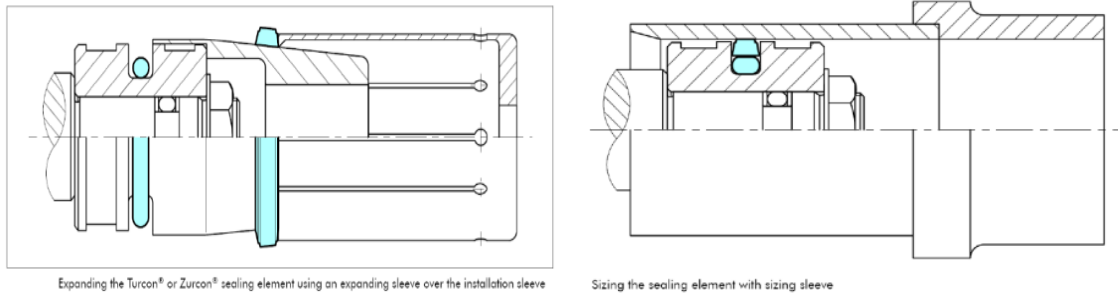

Figure 9 : Installation of seals

The following points should be observed before installation of the seals:

- Ensure the cylinder tube has a **lead in chamfer**
- Remove all residues such as chips, dirt and other foreign particles thoroughly and carefully clean all areas in the cylinder including the grooves on the piston and in the end caps
- The seals can be installed more easily if they are greased or oiled. Attention must be paid to the compatibility of the seal materials with these lubricants. Use only **grease without solid additives** (e.g. molybdenum disulphide or zinc sulphide)
- Use no sharp-edged installation tools

5.2.2 Rod Seals

- Place the O-Ring into the groove
- Compress the outer seals into a kidney shape
- The seal must have no sharp bends as shown in figure 9
- Place the seal ring in compressed form into the groove and push against the O-Ring in the direction of the arrow
- After placing into the groove, form the seal into a ring again in the groove by hand as shown in figure 10
- Finally size the seal ring using a mandrel which should have a chamfer of 10° to 15° over a length of approximately 30mm
- It should be made up of polymer material (e.g. polyamide) with good sliding characteristics and high surface quality in order to avoid damage to the seals
- The Piston rod itself can be used for calibration

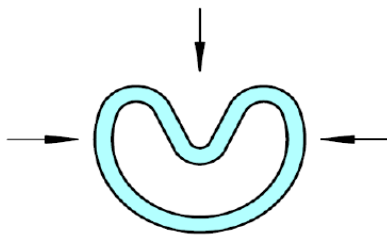

Figure 10 : Kidney-shaped deformation of the seal ring

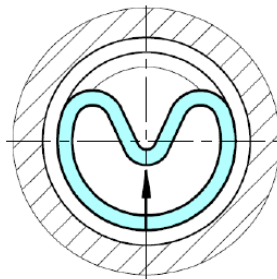

Figure 11 : Inserting the seal ring into the closed groove

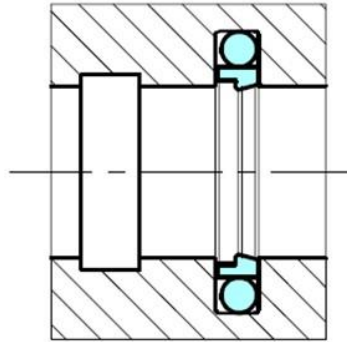

Figure 12 : Inserting the seal ring into the closed groove

5.3 Stepwise Procedure of Actuator Assembly

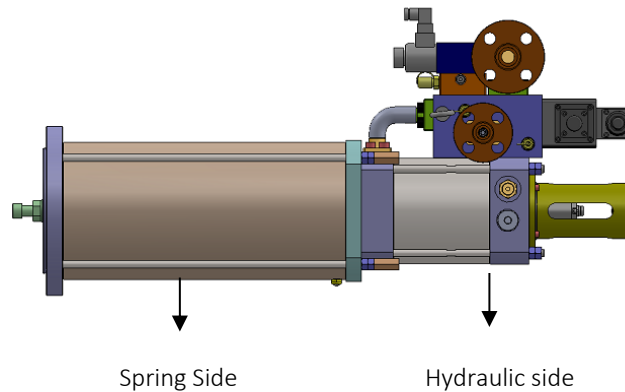

Figure 13 : Assembly of Hydraulic cylinder side

After proper alignment of Front Flange, Rear flange Piston Rod, Piston Head and Tube of Hydraulic Cylinder side, insert the Tie rods into the front Flange so that there is enough engagement in the rear Flange, when completely tightened, the tie rod is completely in contact to the Flange, the Hex nut and Lock Nut as shown in *Figure 13*.

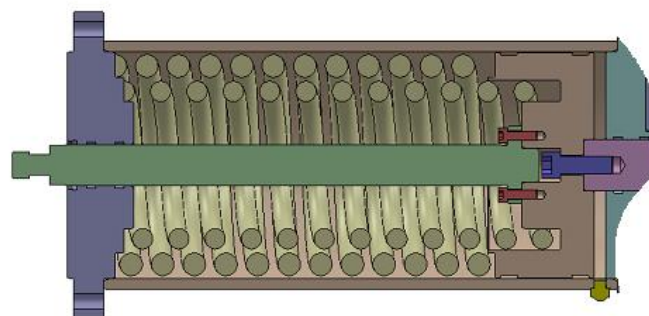

Figure 14 : Springs in actuator

Assemble the Spring Piston Head to hydraulic piston rod and insert the Spring Piston Rod assembly with Head and the place the Spring Tube which is aligned to the end Flange. Place the springs in location of Piston Head and Insert front Flange with proper alignment with other assembly parts. **With the support of hydraulic press**, make sure that there will be the threads of the tie rod available to tighten it as shown in *Figure 14*.

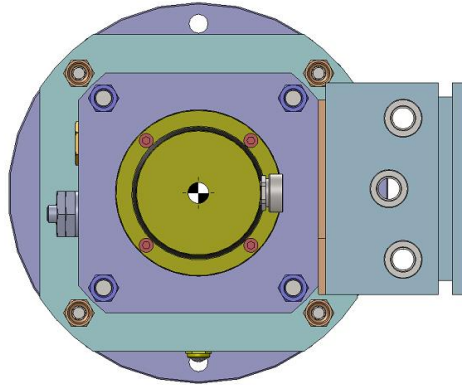

Figure 15 : Assembly

The tightening of Nuts should be done diagonally so that the alignment is even. When completely tightened the Tie-rod is completely in contact with the Front Flange, the Hex nut and Lock Nut as shown in *Figure 15*.

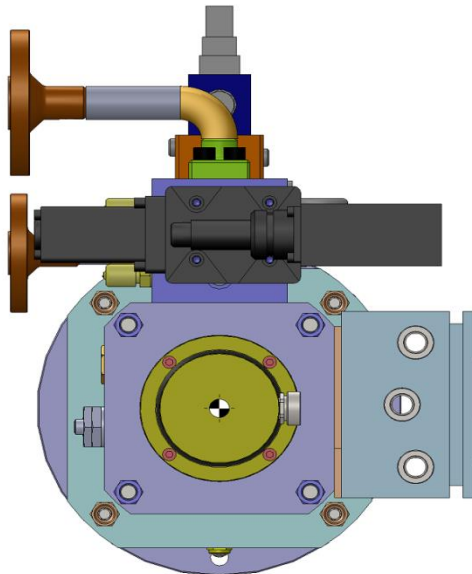

Figure 16 : Final Assembly

Once the actuator is fully assembled with proper torque as suggested in the table – 2 (*Page 28*), mount other valves and components as shown in the installation drawing.

5.4 Actuator Dismantling



! Don't dismantle the actuator at site. It contains highly pre-loaded springs.

5.5 Recommended Preventative Maintenance Guidelines

It is recommended that a visual inspection of the Hydraulic Actuator is done regularly as mentioned below. If anything, out of the ordinary is noticed, contact a qualified maintenance technician immediately.

Daily

Wires & Cables	Visually inspect all wires and cables to verify they are routed in a way that they are not pinched or damaged as the actuator functions
Wires & Cables	Visually inspect all wires and cables to verify that their contacts are secure
Hydraulic Hoses	Visually inspect all hoses to verify they are routed in a way that they are not pinched, tampered or damaged as the actuator functions. Also inspect all hoses for damaged covers, fittings and leaks Inspect and replace according to hose manufacturer's recommendations

Monthly

General	Perform the daily inspections mentioned above and clean the external cylinder parts with a lint free cloth
Swivel Assembly	It is recommended that the torque on joint assembly mounting bolts, is checked every monthly as the bolts could loosen during operation
Mounting bolts	Paint markings fasteners is a convenient way to monitor rotation, but it may not show a loss of fastener clamp load. Refer the torque values as shown in this manual and on the Actuator Installation drawing

6 Months

General	Perform the daily and monthly inspections mentioned above
Hydraulic Fittings	It is recommended that the hydraulic fitting torque is checked at least twice a year as the fittings could be unfastened during operation
SAE Hydraulic Flanges	It is recommended that the bolt torque on the SAE hydraulic flanges are checked at least twice a year as they could be unfastened during operation

Yearly

General	Perform the Daily, Monthly and Bi-annual inspections mentioned above
Oil	Obtain a sample of the oil used in the Hydraulic Powerpack Unit and have the hydraulic oil tested by a hydraulic oil supplier. The oil should be checked for contamination level, contamination type, and for water content

Five Years

General	Perform the inspections mentioned above
Hoses	It is recommended that all hoses to be replaced at this time
Seals	Replace complete seal sets – depending upon usage

5.6 Contamination Control

5.6.1 Sources of Contamination

There are four primary sources where solid contamination that can enter a hydraulic fluid is as follows:

New Oil:

Even using fluids from reputable suppliers, sampling has shown that all new oil needs to be filtered before being used in a hydraulic system to get extend longevity of the components. A portable oil filter fitted with a 3 Micron filter is recommended when filling the oil reservoir of a hydraulic system. By doing this the contamination can be removed from the new oil before the contamination enters and damage critical components in the hydraulic actuator system.

Contamination Due to The Assembly or Repair Process:

New equipment always has a certain level of contamination. Even with careful system assembly, and new component flushing, the amount of contamination is reduced, but is never eliminated. During the assembly process Moog carefully cleans each component before assembly to minimize the amount of contamination. Moog flushes the hydraulic actuator before initial start-up with operation.

Contamination from The Outside Environment:

Contamination from the environment can be ingress into the hydraulic system. The key is to limit the access to the environmental contamination that must enter the hydraulic system. There are four major ways dirt can enter a hydraulic system:

- Reservoir vent ports (Where air breathers are installed)
- Power unit or system access plates
- Components left open during maintenance
- Cylinder seals

All possible care should be taken to ensure that open ports are kept covered or plugged and component disassembly and rework is done in an area that is protected from excessive airborne dirt and contamination. An air breather with a filter is recommended. A Desiccant air breather which also prevents water ingress is preferred. Lint free rags should be used to clean Hydraulic components.

Internally-Generated Contamination from Worn Components:

Contamination is generated by the system itself during normal operation. In a properly filtered system running on clean fluid, particles are generated. Components, such as pumps creates metal particles due to component wear during normal operation.

5.6.2 ISO Cleanliness Recommendation

The best way to minimize internal contamination generation within a hydraulic system and maximize the longevity of the hydraulic components is to start with a clean (fully flush) system and maintain the system fluid to the recommended ISO cleanliness levels. The Proportional valves are the most sensitive components in the hydraulic

Operation and Maintenance Manual

system to contamination due to the very low tolerances needed for high performance. For the hydraulic test actuator, Moog recommends the following ISO cleanliness levels:

- For Normal Life: ISO 4406 < 18 / 15 / 13
- For Extended Life: ISO 4406 < 17 / 15 / 12

The chart below explains the ISO code.

NAS 1638	4	5	6	7	8	9	10	11
ISO 4406-1999	15/13/10	16/14/11	17/15/12	18/16/13	19/17/14	20/18/15	21/19/16	22/20/17

ISO 4406

First number: particles greater than 4µm
 Second number: particles greater than 6µm
 Third number: particles greater than 14µm

ISO/Range Code	Min. particles /mL	Max particles /mL
1	0	0.02
2	0.02	0.04
3	0.04	0.08
4	0.08	0.15
5	0.15	0.3
6	0.3	0.6
7	0.6	1.3
8	1.3	2.5
9	2.5	5
10	5	10
11	10	20
12	20	40
13	40	80
14	80	160
15	160	320
16	320	640
17	640	1,300
18	1,300	2,500
19	2,500	5,000
20	5,000	10,000
21	10,000	20,000
22	20,000	40,000
23	40,000	80,000
24	80,000	160,000
25	160,000	320,000
26	320,000	640,000
27	640,000	1,300,000
28	1,300,000	2,500,000
29	2,500,000	5,000,000
30	5,000,000	10,000,000

Table 1 : ISO Cleanliness Code

5.7 Calibration Reference

Actuator Stroke Calibration in PI Amplifier

Please note the following:

- for 4mA Governor Command => cylinder is Retracted and
- for 20mA Governor Command => cylinder is Extended



Attention!

The PI Servo amplifier is pre calibrated with full stroke of the actuator i. e 80mm. If you want to restrict the actuator stroke to say for example 60mm or if the linearity is disturbed then we have to follow the below procedure.

1. Disconnect the Governor command + from P-I Amplifier Pin 7.
2. Disconnect the Servo command + from P-I Amplifier Pin 31 (Servo Valve Pin D)
3. Connect a digital multi-meter (DMM), on DC Volts, between the front panel feedback amp and ground test points.
4. Connect the current source or Governor command (isolator output) (4-20mA) to the Servo Valve Pin D directly. (Make sure that current source / Governor command (isolator output) GND and Servo valve GND are same.)
5. Do not disturb the other connections.
6. Apply 4mA command (i.e., 0%) from the Governor, the actuator will be in extended position.
7. Adjust the feedback Zero trimpot until the digital multi-meter (DMM) reads 0.00V.
8. Then provide a spacer / metal block for required stroke of the actuator say for example 60mm.
*If there is NO spacer available, then you can use the following formula (Point –Slope form).
(-10/x[mm]) *80 = -y[V] where x is required stroke in mm & y is V to be set at max. stroke
i.e., (-10/60[mm]) *80 = -13.33V*
9. Now, Apply 12 to 20mA command from the current source or Governor command (i.e., 50 to 100%).
The actuator will retract until the spacer / metal block provided.
If there is no spacer then actuator will reach the full stroke.
10. Adjust the feedback Gain trimpot until the digital multi-meter (DMM) reads -10.00V.
If there is no spacer, then set -y[V] (for 60mm -13.33V)
11. Repeat Step 6, check the feedback test point is still 0.00V. Trim if necessary and check the 0.00V setting again.
12. Repeat Step 9, check the feedback test point is still -10.00V (If there is no spacer, then -y[V] for 60mm -13.33V) Trim if necessary and check the -10.00V setting again.
13. Finally connect the Governor command + to P-I Amplifier Pin 7 and Servo command + to P-I Amplifier Pin 31 (Servo Valve Pin D).
14. Now apply the Governor command in steps of 10% until 100% and measure the actuator stroke with Digital Vernier caliper. Check for the actuator stroke linearity. Trim FB amp gain and zero to minimise any positioning errors.
15. Ensure the actuator travels to 100% stroke for 100% or slightly less Governor command.

5.8 Recommended Spares

Sl. No	Description	Moog Part No.	Qty
1	Proportional Valve	D634-1005	1Pc
2	Emergency Solenoid Valve	X820-21PA-001N01	1Pc
3	Cartridge Valve	X731-016BOS-000N00	1Pc
4	PI Amplifier	G122-829A011	1Pc
5	Actuator Seal Kit	CC85872	1set
6	Position Transducer	CC51375	1Pc
7	Flushing plate	CC32673	1set
8	Minimess Hose 1mtr length with Pr. Gauge 4"dial, 0-40bar glycerine filled	CC01747	1set

Table 2 : Recommended Spares

5.9 Tightening Torque

The following tightening torques, and assembly preloads apply to the screws with metric thread specified below:

- Allen screws in accordance with DIN 912
- Hexagon head bolts in accordance with DIN 931
- Property class 10.9 according to DIN ISO 898 $\mu=0,1$
- Head contact surface and thread lubricated with MoS2

THREAD	PRELAOD	TIGHTENING TORQUE
M5	9.7kN	7Nm
M6	14.3kN	12.5Nm
M8	26kN	30Nm
M10	42kN	60Nm
M12	61kN	104Nm
M14	84kN	165Nm
M16	115kN	250Nm
M20	180kN	490Nm
M24	260kN	850Nm
M30	415kN	1700Nm
M36	600kN	3000Nm
M42	850kN	4800Nm
M48	1100kN	7200Nm
M48 x 3	1200kN	7500Nm

Table 3 : Tightening Torques

6.0 Actuator Trouble Shooting - Possible Causes and Remedies

6.1 No Response from the Actuator

Control oil pressure is low:

- *Check the inlet pressure (14kg/cm²)*

No Power supply for PI Amplifier / Proportional valve / Position sensor / Emergency Solenoid valve:

- *Check the input power supply (24VDC)*

No signals to PI Amplifier / Proportional valve / Position sensor:

- *Check all signals are arriving at actuator Junction Box*

Loss of command signal / Cable damages / Puncture in cables:

- *Check the cable conditions by continuity / insulation test*

Corrosion in mating connectors:

- *Clean / replace the mating connectors*

PI Amplifier - failure of cable break detector circuit due to current >30mA:

- *Check the wiring and then replace PI Amplifier*

Proportional valve - failure of valve internal electronics due to wrong wiring / improper earthing & shielding / welding when the valve is ON:

- *Check the wiring / remove the connector while welding. Replace proportional valve if malfunctioning*

Proportional valve - No movement of pilot / main spool due to contamination:

- *Identify the source of contamination and flush the circuit and then replace Proportional valve*

Position sensor - failure of internal electronics due to wrong wiring / improper earthing & shielding / welding when the valve is ON / high temperature:

- *Check the wiring / remove the connector while welding / provide additional heat insulator and then replace position sensor*

Emergency Solenoid valve - No spool movement due to contamination:

- *Identify the source of contamination and flush the circuit and then replace Solenoid valve*

6.2 External Leakages from Actuator

Rod seal worn out:

- *Replace the seals. Keep the surroundings free from dust / metal particles. Check for misalignment*

Loose parts:

- *Tighten parts with appropriate torque*

Piston rod damages:

- *Check rod for dent marks or scratches that could lead to seal damage or allow oil leakage. Replace the damaged rod*

6.3 The Control Oil Inlet Pressure Drops When Governor Command is Given

Malfunctioning of Emergency solenoid / Cartridge valve:

- *Replace the Emergency solenoid / Cartridge valve or spring, seals*

6.4 Abnormal Noise from the Actuator

Aeration or cavitation:

- *Bleed the air by stroking the actuator several times / Check the pump shaft bearing / Oil level continuity / insulation test*

6.5 Wire break detection not working

PI Amplifier - failure of cable break detector circuit due:

- *Check the wiring and then replace PI Amplifier to wrong wiring (current >30mA)*

6.6 System operates erratically

Air in system:

- *Examine suction side of the pump*

Spool sticking or binding:

- *Check for dirt or gummy deposits, if contaminated, try to find the source of contamination*

Dirt in Emergency Solenoid Valve:

- *Clean the valve or replace*

Restriction in pressure line filter:

- *Replace filter element*

7.0 Annexure Documents

1. General Assembly Drawing: S074639-001 P2
2. Servo Valve catalogue: D634P
3. Emergency Solenoid Valve catalogue: X820
4. Servo Amplifier: G122-829A011

MOOG ENGINEERING ON CALL FOR YOU

Working with Moog means total access to a team of specialists who are committed to your needs long after your solution is delivered.

Our expert engineers are on call across the globe, ready to respond quickly and professionally to help you get the most from your investment. From helping you minimize downtime to keeping your systems working at peak effectiveness, Moog specialists understand the special demands of actuation for strength and durability testing. We're there when you need us.

In order to solve your problem most efficiently we ask you to retrieve the information from the nameplate attached to the component (actuator, manifold, controller, etc) and have it available when discussing the problem.

TAKE A CLOSER LOOK

Polymer Bearing Actuator test solutions from Moog are available around the world. For more information, visit our web site or contact one of the locations below.

Argentina
+54 11 4326 5916
info.argentina@moog.com

India
+91 80 4057 6605
info.india@moog.com

Singapore
+65 677 36238
info.singapore@moog.com

Australia
+61 3 9561 6044
info.australia@moog.com

Ireland
+353 21 451 9000
info.ireland@moog.com

South Africa
+27 12 653 6768
info.southafrica@moog.com

Brazil
+55 11 3572 0400
info.brazil@moog.com

Italy
+39 0332 421 111
info.italy@moog.com

Spain
+34 902 133 240
info.spain@moog.com

Canada
+1 716 652 2000
info.canada@moog.com

Japan
+81 46 355 3767
info.japan@moog.com

Sweden
+46 31 680 060
info.sweden@moog.com

China
+86 21 2893 1600
info.china@moog.com

Korea
+82 31 764 6711
info.korea@moog.com

Switzerland
+41 71 394 5010
info.switzerland@moog.com

Finland
+358 9 2517 2730
info.finland@moog.com

Luxembourg
+352 40 46 401
info.luxembourg@moog.com

United Kingdom
+44 168 429 6600
info.uk@moog.com

France
+33 1 4560 7000
info.france@moog.com

The Netherlands
+31 252 462 000
simulation@moog.com

USA
+1 716 687 7600
info.usa@moog.com

Germany
+49 7031 6220
info.germany@moog.com

Norway
+47 6494 1948
info.norway@moog.com

Hong Kong
+852 2 635 3200
info.hongkong@moog.com

Russia
+7 8 31 713 1811
info.russia@moog.com

www.moog.com/industrial

Moog is a registered trademark of Moog Inc. All trademarks as indicated herein are the property of Moog Inc. and its subsidiaries.
©2011 Moog Inc. All rights reserved.

Hydraulic Test Actuator - Polymer Bearing CDL 26496 Rev H 0511
TJW/PDF